

NOTE: BREAK ALL CORNERS WITH 0.015" (.38 MM) RADIUS UNLESS OTHERWISE NOTED. STANDARD TOLERANCES TO APPLY UNLESS OTHERWISE SPECIFIED.

CUSTOMER PART No.	CUSTOMER CAN ART STD.	DIE No. EH05763
DESCRIPTION 1.500 x 1.000 x .090 W/ .125 RADIUS	PROPOSAL No. H-50722	

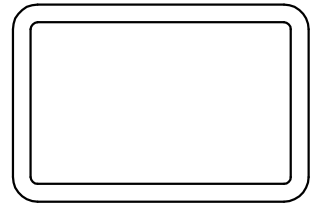
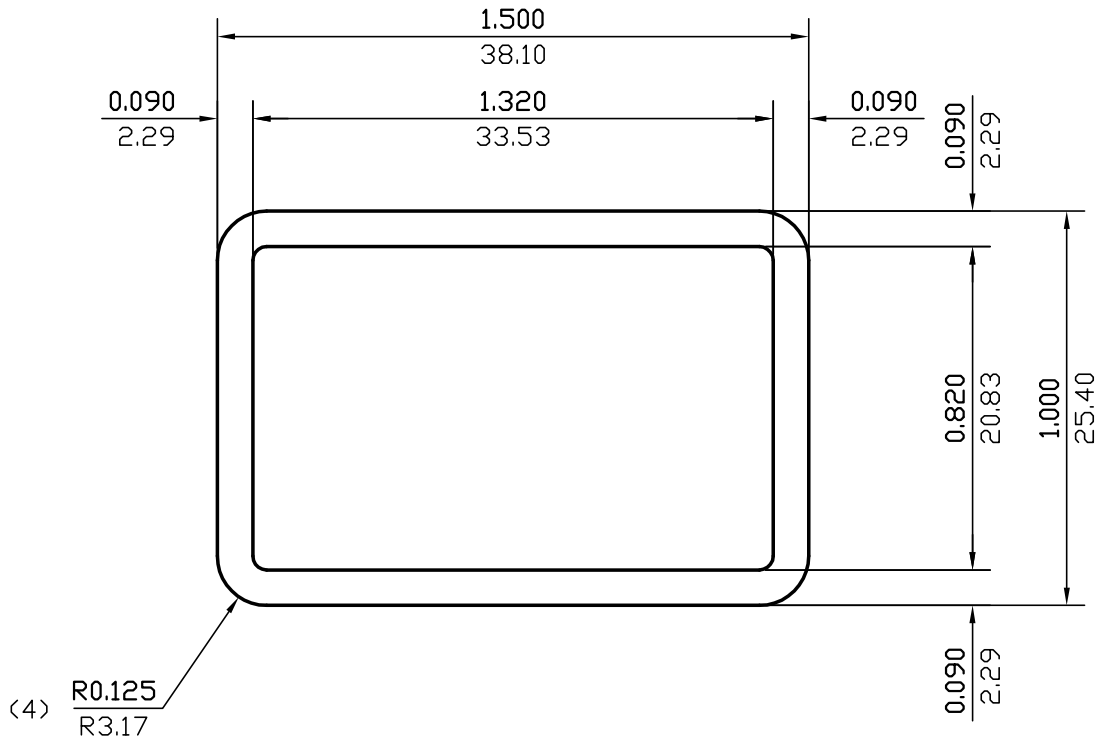

ACTUAL SIZE

WALL THICKNESS 0.090(2.29) EXCEPT AS SHOWN

DATE	REV	DESCRIPTION	BY
EST.AREA	0.405	IN. ²	EST.AREA 261.446
EST.WT.	0.486	LBS/FT.	EST.WT. 0.724
EST.PER.	9.005	IN.	EST.PER. 228.735
OUT PER.	4.785	IN.	OUT PER. 121.5
C.C.D.	1.701	IN.	C.C.D. 43.214
FACTOR	19	FINISH	M/F
		ALLOY & TEMP.	6005A
CKD BY	SCALE 2:1	DWN BY	L.L. DATE 05/28/2002

CAN ART

428 JUTRAS DRIVE S.
WINDSOR, ONT. N8N 5C5
TEL. NO. (519) 727-4399
FAX NO. (519) 727-6434
E-MAIL: canart@canart.com

ALUMINUM EXTRUSION INC.

THIS DRAWING IS NOT NECESSARILY A COPY OF YOUR ORIGINAL. PLEASE APPROVE DIMENSIONS AND TOLERANCES INDICATED. CAN ART ASSUMES NO RESPONSIBILITY EITHER TECHNICAL OR LEGAL FOR HAVING THIS SHAPE MADE. THE CUSTOMER AGREES TO FULLY PROTECT CAN ART ALUMINUM FROM CLAIMS OF OTHERS RESULTING FROM THIS SHAPE.

SIGNED: _____ DATE: _____