

NOTE: BREAK ALL CORNERS WITH 0.015" (.38 MM) RADIUS UNLESS OTHERWISE NOTED. STANDARD TOLERANCES TO APPLY UNLESS OTHERWISE SPECIFIED.

CUSTOMER CAN ART STD.	DIE No. EH62680	REV. No. 3
DESCRIPTION 4.000 x 0.375 THK. SQ. TUBE	CUSTOMER PART No.	PROPOSAL No. H-22595
	QUOTE No. 10-0422-1	

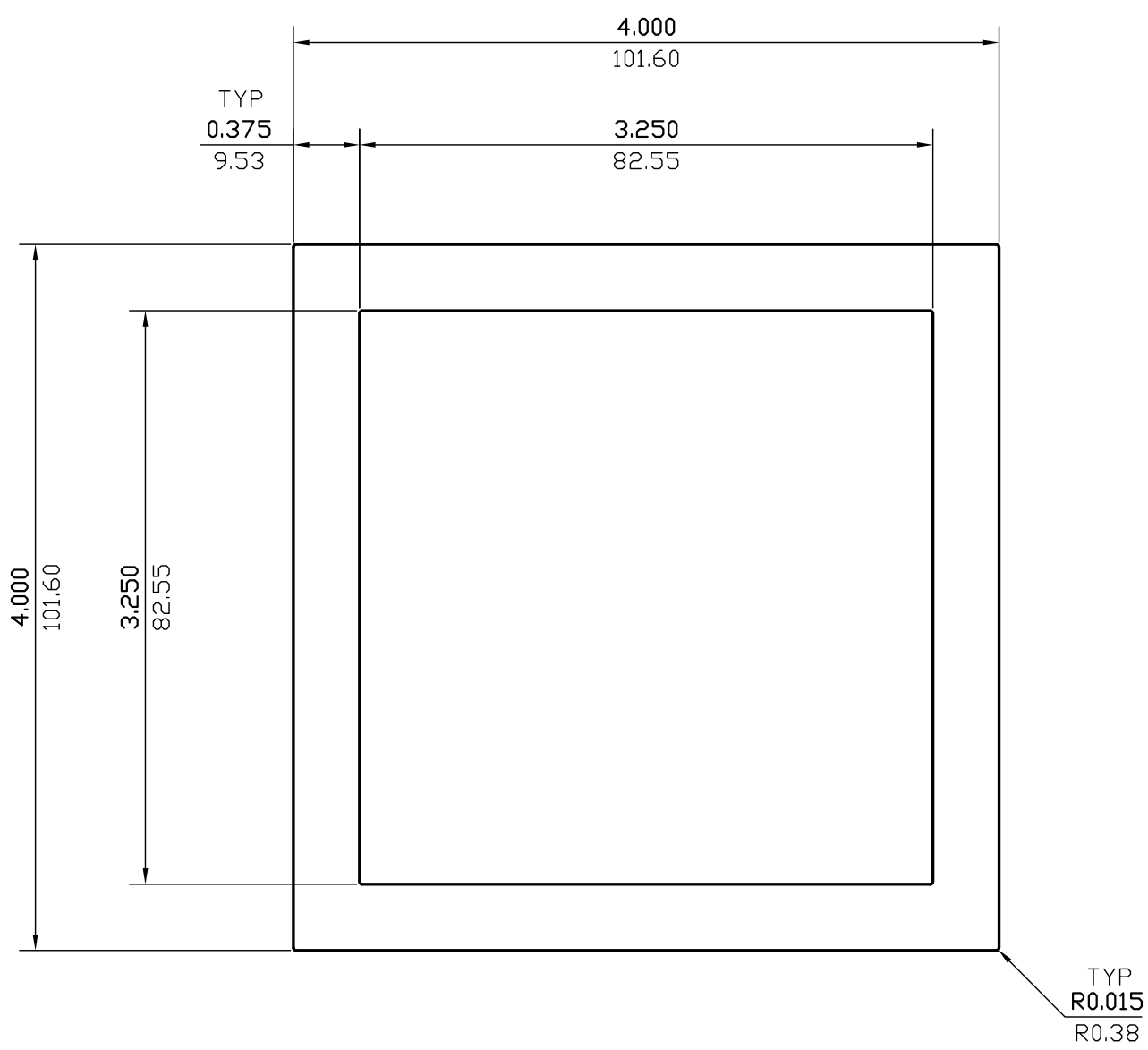

WALL THICKNESS **0.375 (9.53)** EXCEPT AS SHOWN

DATE	REV	DESCRIPTION	BY
08/30/23	3	REMOVED I.D. MARK	JASDN
03/13/23	2	REMOVED ALLOY	JASDN
EST.AREA	5.438	IN. ²	EST.AREA 3508.085 MM. ²
EST.WT.	6.416	LBS/FT.	EST.WT. 9.549 KG/M.
EST.PER.	28.948	IN.	EST.PER. 735.292 MM.
OUT PER.	15.974	IN.	OUT PER. 405.7 MM.
C.C.D.	5.644	IN.	C.C.D. 143.368 MM.
FINISH	M/F		ALLOY
CKD BY	FACTOR 5	SCALE 1:1	DWN BY P.M. DATE 04/01/2010

CAN ART

85 PARKSHORE DRIVE
BRAMPTON, ONT L6T 5M1
TEL. NO. (905) 791-1464
FAX NO. (905) 791-9151
WEB: www.canart.com

ALUMINUM EXTRUSION INC.

THIS DRAWING IS NOT NECESSARILY A COPY OF YOUR ORIGINAL. PLEASE APPROVE DIMENSIONS AND TOLERANCES INDICATED. CAN ART ASSUMES NO RESPONSIBILITY EITHER TECHNICAL OR LEGAL FOR HAVING THIS SHAPE MADE. THE CUSTOMER AGREES TO FULLY PROTECT CAN ART ALUMINUM FROM CLAIMS OF OTHERS RESULTING FROM THIS SHAPE.

SIGNED: _____ DATE: _____