

CUSTOMER

CAN ART STD.

DIE No.

EH05845

REV. No.

0

DESCRIPTION

4.000 x .188 SQUARE TUBE

CUSTOMER PART No.

QUOTE No.

L07-0510-4

PROPOSAL No.

H-55767

NOTE: BREAK ALL CORNERS WITH 0.015" (.38 MM) RADIUS UNLESS OTHERWISE NOTED. STANDARD TOLERANCES TO APPLY UNLESS OTHERWISE SPECIFIED.

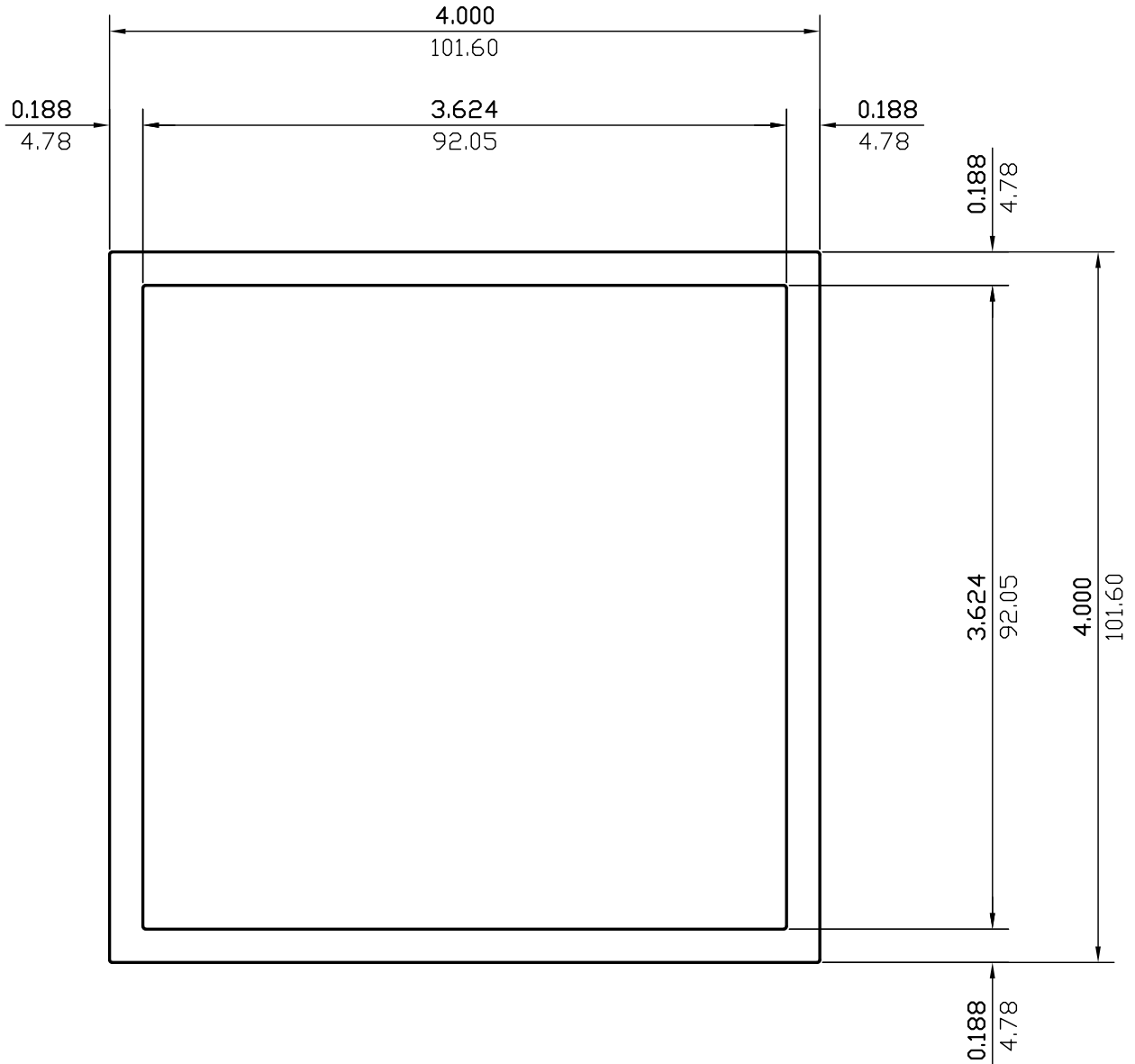

WALL THICKNESS 0.188(4.78) EXCEPT AS SHOWN

DATE	REV	DESCRIPTION		BY	
EST.AREA	2.867	IN. ²	EST.AREA	1849.446	MM. ²
EST.WT.	3.440	LBS/FT.	EST.WT.	5.119	KG/M.
EST.PER.	30.444	IN.	EST.PER.	773.290	MM.
OUT PER.	15.974	IN.	OUT PER.	405.7	MM.
C.C.D.	5.636	IN.	C.C.D.	143.146	MM.
FINISH	M/F		ALLOY	6063	
CKD BY	FACTOR	SCALE	DWN BY	DATE	
	9	1:1	L.G.	12/12/2007	

CAN ART

ALUMINUM EXTRUSION INC.

428 JUTRAS DRIVE S.
WINDSOR, ON N8N 5C5
TEL. NO. (519) 727-4399
FAX NO. (519) 727-6434
WEB: www.canart.com

THIS DRAWING IS NOT NECESSARILY A COPY OF YOUR ORIGINAL. PLEASE APPROVE DIMENSIONS AND TOLERANCES INDICATED. CAN ART ASSUMES NO RESPONSIBILITY EITHER TECHNICAL OR LEGAL FOR HAVING THIS SHAPE MADE. THE CUSTOMER AGREES TO FULLY PROTECT CAN ART ALUMINUM FROM CLAIMS OF OTHERS RESULTING FROM THIS SHAPE.

SIGNED: _____ DATE: _____