

NOTE: BREAK ALL CORNERS WITH 0.015" (.38 MM) RADIUS UNLESS OTHERWISE NOTED. STANDARD TOLERANCES TO APPLY UNLESS OTHERWISE SPECIFIED.

CUSTOMER	CAN ART STD.	DIE No.	EH05992	REV. No.	0
DESCRIPTION	2.500 x 0.250 SQ. TUBE	CUSTOMER PART No.	QUOTE No.	PROPOSAL No.	
			11-1030-1	H-25171	

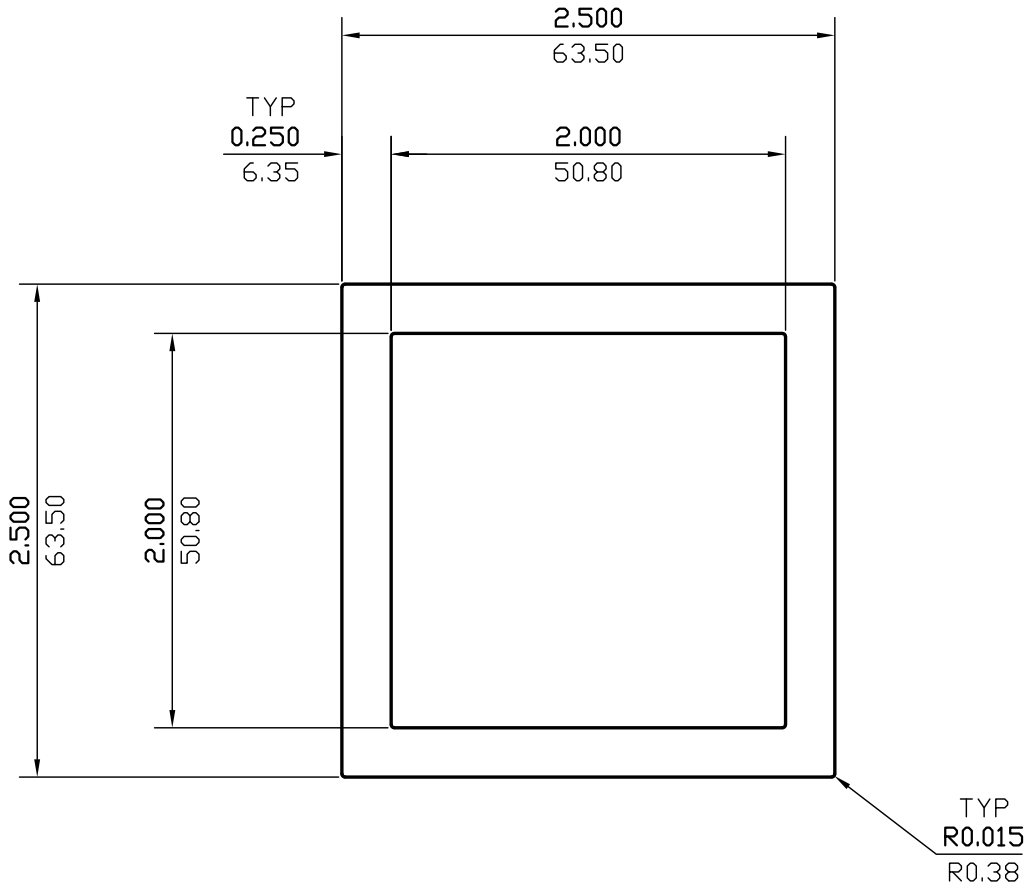

WALL THICKNESS 0.250 (6.35) EXCEPT AS SHOWN

DATE	REV	DESCRIPTION	BY
EST.AREA	2.250	IN. ²	EST.AREA 1451.621
			MM. ²
EST.WT.	2.655	LBS/FT.	EST.WT. 3.951
			KG/M.
EST.PER.	17.948	IN.	EST.PER. 455.892
			MM.
OUT PER.	9.974	IN.	OUT PER. 253.3
			MM.
C.C.D.	3.523	IN.	C.C.D. 89.487
			MM.
FINISH	M/F		ALLOY 6061
CKD BY	FACTOR 7	SCALE 1:1	DWN BY P.M. DATE 11/02/2011

CAN ART

ALUMINUM EXTRUSION INC.

85 PARKSHORE DRIVE
BRAMPTON, ONT L6T 5M1
TEL. NO. (905) 791-1464
FAX NO. (905) 791-9151
WEB: www.canart.com

THIS DRAWING IS NOT NECESSARILY A COPY OF YOUR ORIGINAL. PLEASE APPROVE DIMENSIONS AND TOLERANCES INDICATED. CAN ART ASSUMES NO RESPONSIBILITY EITHER TECHNICAL OR LEGAL FOR HAVING THIS SHAPE MADE. THE CUSTOMER AGREES TO FULLY PROTECT CAN ART ALUMINUM FROM CLAIMS OF OTHERS RESULTING FROM THIS SHAPE.

SIGNED: _____ DATE: _____