

CUSTOMER

CAN ART STD.

DIE No.

EH05810

REV. No.

0

DESCRIPTION

2.000 x 0.188 THK. SQUARE TUBE

CUSTOMER PART No.

PROPOSAL No.

H-15626

NOTE: BREAK ALL CORNERS WITH 0.015" (.38 MM) RADIUS UNLESS OTHERWISE NOTED. STANDARD TOLERANCES TO APPLY UNLESS OTHERWISE SPECIFIED.

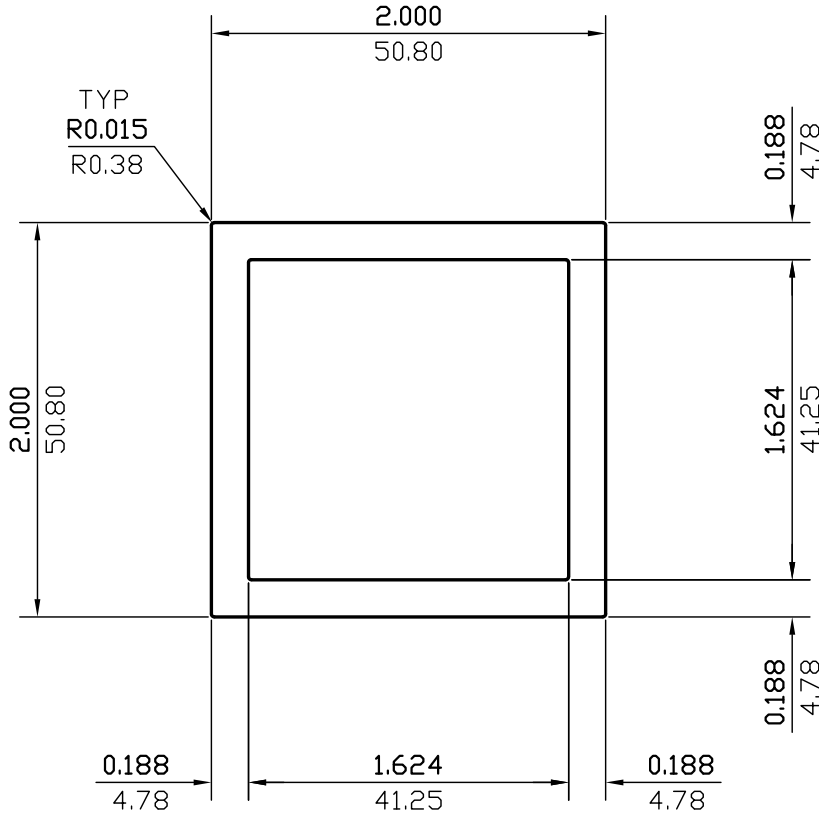

WALL THICKNESS **0.188 (4.78)** EXCEPT AS SHOWN

DATE	REV	DESCRIPTION	BY
EST.AREA	1.363	IN. ²	EST.AREA 879.117 MM. ²
EST.WT.	1.608	LBS/FT.	EST.WT. 2.393 KG/M.
EST.PER.	14.444	IN.	EST.PER. 366.890 MM.
OUT PER.	7.974	IN.	OUT PER. 202.5 MM.
C.C.D.	2.816	IN.	C.C.D. 71.526 MM.
FINISH	M/F		ALLOY 6063
CKD BY	FACTOR 9	SCALE 1:1	DWN BY P.M. DATE 03/29/2005

CAN ART

ALUMINUM EXTRUSION INC.

85 PARKSHORE DRIVE
BRAMPTON, ONT L6T 5M1
TEL. NO. (905) 791-1464
FAX NO. (905) 791-9151
WEB: www.canart.com

THIS DRAWING IS NOT NECESSARILY A COPY OF YOUR ORIGINAL. PLEASE APPROVE DIMENSIONS AND TOLERANCES INDICATED. CAN ART ASSUMES NO RESPONSIBILITY EITHER TECHNICAL OR LEGAL FOR HAVING THIS SHAPE MADE. THE CUSTOMER AGREES TO FULLY PROTECT CAN ART ALUMINUM FROM CLAIMS OF OTHERS RESULTING FROM THIS SHAPE.

SIGNED: _____ DATE: _____