

CUSTOMER PART No.

CUSTOMER

# CAN ART OPEN

DIE No.

EH09741

DESCRIPTION

1.5 x 1.5 x .125 SQ. TUBE

PROPOSAL No.

H-7593

NOTE: BREAK ALL CORNERS WITH 0.015" (.38 MM) RADIUS UNLESS OTHERWISE NOTED. STANDARD TOLERANCES TO APPLY UNLESS OTHERWISE SPECIFIED.

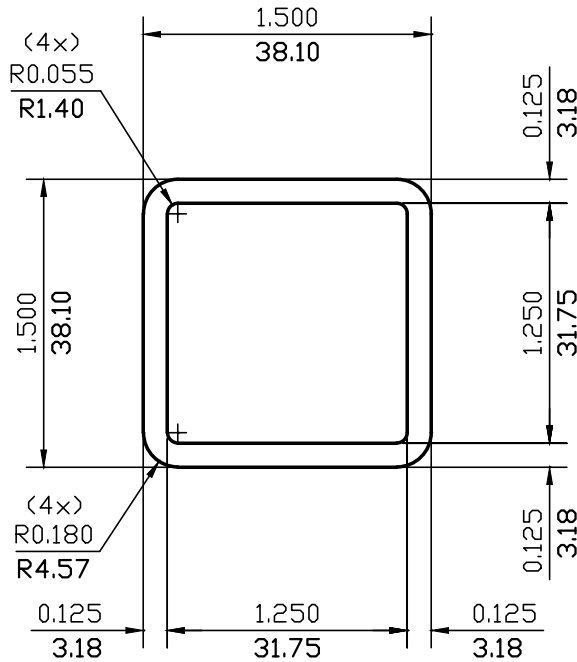

WALL THICKNESS 0.125(3.18) EXCEPT AS SHOWN

DATE	REV	DESCRIPTION	BY
EST.AREA	0.662	IN. <sup>2</sup>	EST.AREA 427.283
EST.WT.	0.795	LBS/FT.	EST.WT. 1.183
EST.PER.	10.597	IN.	EST.PER. 269.152
OUT PER.	5.691	IN.	OUT PER. 144.6
C.C.D.	1.972	IN.	C.C.D. 50.094
FACTOR 13	FINISH M/F	ALLOY & TEMP. 6063-T5	
CKD BY	SCALE 1:1	DWN BY C.P.	DATE 04/14/98

## CAN ART

ALUMINUM EXTRUSION INC.

85 PARKSHORE AVE.  
BRAMPTON, ONT. L6T 5M1  
TEL. NO. (905) 791-1464  
FAX NO. (905) 791-9151  
E-MAIL: canart@canart.com

THIS DRAWING IS NOT NECESSARILY A COPY OF YOUR ORIGINAL. PLEASE APPROVE DIMENSIONS AND TOLERANCES INDICATED. CAN ART ASSUMES NO RESPONSIBILITY EITHER TECHNICAL OR LEGAL FOR HAVING THIS SHAPE MADE. THE CUSTOMER AGREES TO FULLY PROTECT CAN ART ALUMINUM FROM CLAIMS OF OTHERS RESULTING FROM THIS SHAPE.

SIGNED: \_\_\_\_\_ DATE: \_\_\_\_\_