

NOTE: BREAK ALL CORNERS WITH 0.015" (.38 MM) RADIUS UNLESS OTHERWISE NOTED. STANDARD TOLERANCES TO APPLY UNLESS OTHERWISE SPECIFIED.

CUSTOMER PART No.	CUSTOMER CAN ART OPEN	DIE No. EH05189
DESCRIPTION		PROPOSAL No.

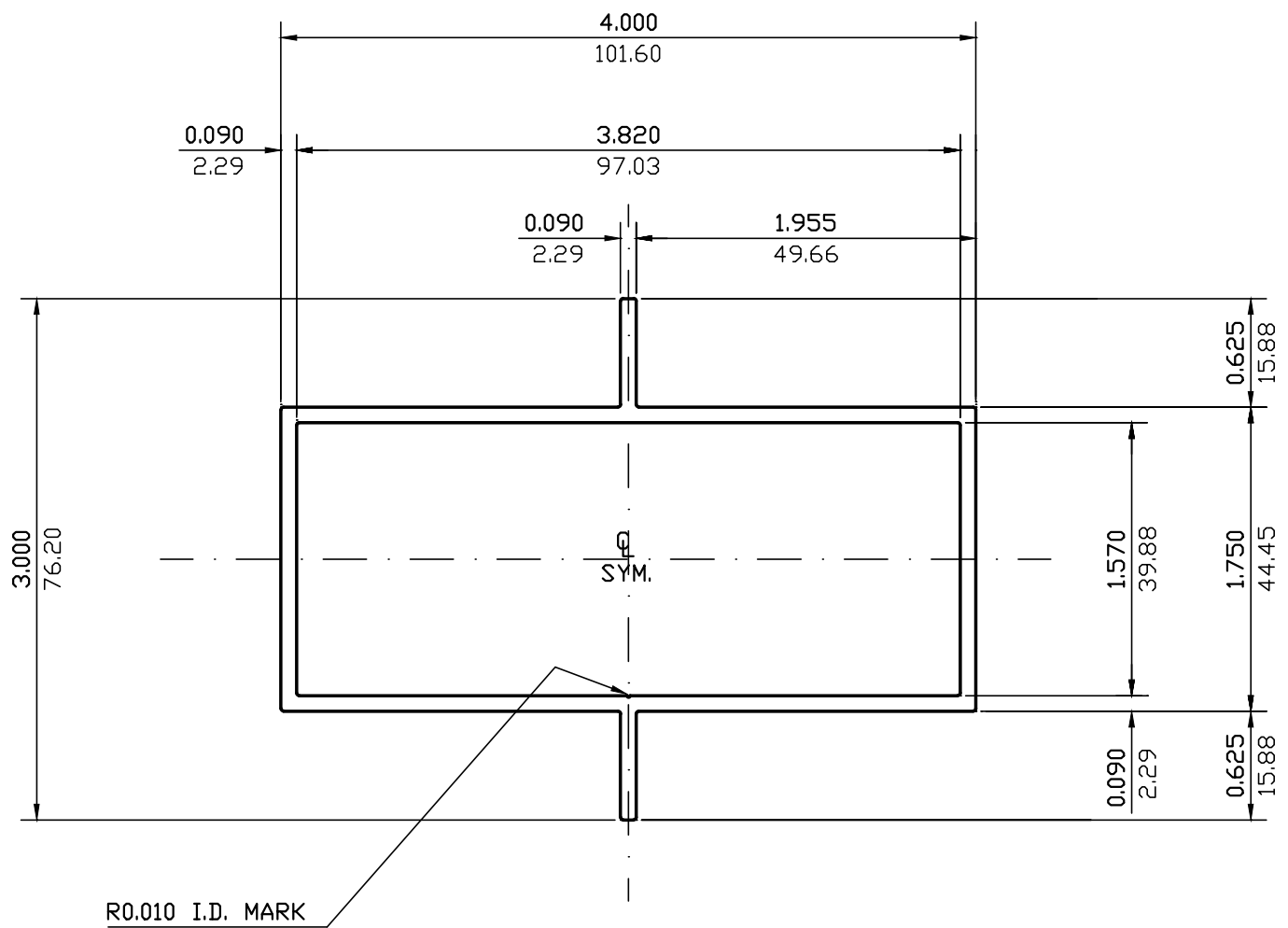

R0.010 I.D. MARK

ALL OUTSIDE SURFACE EXPOSED

WALL THICKNESS 0.090 (2.29) EXCEPT AS SHOWN

DATE	REV	DESCRIPTION	BY
EST.AREA	1.115	IN. ²	EST.AREA 719
EST.WT.	1.316	LBS/FT.	EST.WT. 1.958
EST.PER.	24.791	IN.	EST.PER. 629.7
OUT PER.	14.000	IN.	OUT PER. 355.6
C.C.D.	4.366	IN.	C.C.D. 111
FACTOR	19	FINISH PAINT/ANOD.	ALLOY & TEMP. 6063
CKD BY	SCALE 1:1	DWN BY G.M.	DATE 02/07/89

CAN ART

ALUMINUM EXTRUSION INC.

85 PARKSHORE DRIVE
BRAMPTON, ONT L6T 5M1
TEL. NO. (905) 791-1464
FAX NO. (905) 791-9151
E-MAIL: canart@canart.com

THIS DRAWING IS NOT NECESSARILY A COPY OF YOUR ORIGINAL. PLEASE APPROVE DIMENSIONS AND TOLERANCES INDICATED. CAN ART ASSUMES NO RESPONSIBILITY EITHER TECHNICAL OR LEGAL FOR HAVING THIS SHAPE MADE. THE CUSTOMER AGREES TO FULLY PROTECT CAN ART ALUMINUM FROM CLAIMS OF OTHERS RESULTING FROM THIS SHAPE.

SIGNED: _____ DATE: _____