

CUSTOMER PART No.

CUSTOMER

CAN ART STD.

DIE No.

EH05245

DESCRIPTION

0.500" O.D. x 0.065" THK. ROUND TUBE

PROPOSAL No.

H-1864

NOTE: BREAK ALL CORNERS WITH 0.015" (.38 MM) RADIUS UNLESS OTHERWISE NOTED. STANDARD TOLERANCES TO APPLY UNLESS OTHERWISE SPECIFIED.

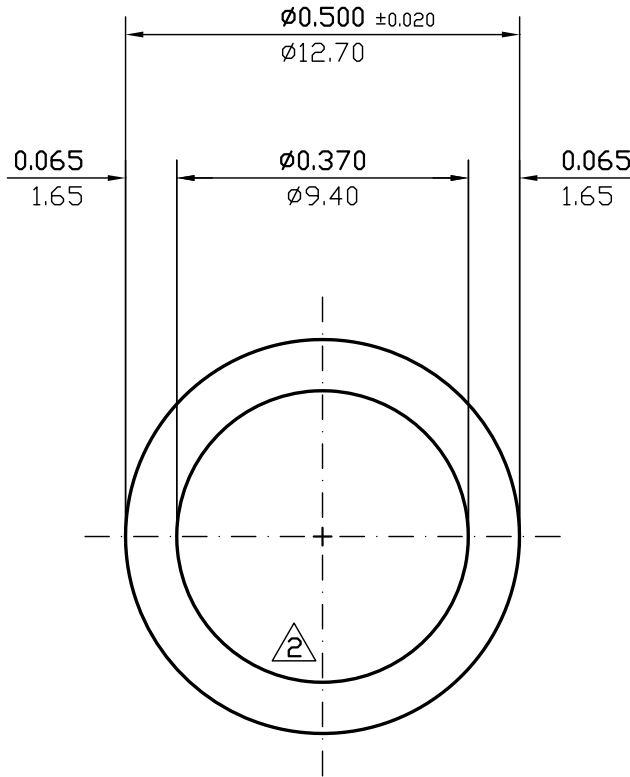

ACTUAL SIZE

WALL THICKNESS 0.065 (1.65) EXCEPT AS SHOWN

DATE	REV	DESCRIPTION	BY
03/10/23	3	REMOVED ALLDY	JASON
10/23/03	2	REMOVED EXPOSED. REMOVED I.D. MARK. REVISED WTS & MEASURE.	PAUL
EST.AREA	0.089	IN. ²	EST.AREA 57
			MM. ²
EST.WT.	0.105	LBS/FT.	EST.WT. 0.156
			KG/M.
EST.PER.	2.745	IN.	EST.PER. 69.7
			MM.
OUT PER.	1.571	IN.	OUT PER. 39.9
			MM.
C.C.D.	0.500	IN.	C.C.D. 13
			MM.
FACTOR	26	FINISH	M/F
		ALLOY & TEMP.	
CKD BY	SCALE	4:1	DWN BY G.M. DATE 02/05/91

CAN ART

ALUMINUM EXTRUSION INC.

85 PARKSHORE DRIVE
BRAMPTON, ONT L6T 5M1
TEL. NO. (905) 791-1464
FAX NO. (905) 791-9151
E-MAIL: canart@canart.com

THIS DRAWING IS NOT NECESSARILY A COPY OF YOUR ORIGINAL. PLEASE APPROVE DIMENSIONS AND TOLERANCES INDICATED. CAN ART ASSUMES NO RESPONSIBILITY EITHER TECHNICAL OR LEGAL FOR HAVING THIS SHAPE MADE. THE CUSTOMER AGREES TO FULLY PROTECT CAN ART ALUMINUM FROM CLAIMS OF OTHERS RESULTING FROM THIS SHAPE.

SIGNED: _____ DATE: _____