

CUSTOMER PART No.	CUSTOMER	CAN ART OPEN	DIE No.
			ES60046
DESCRIPTION	WEB CHANNEL		PROPOSAL No. S-50149

NOTE: BREAK ALL CORNERS WITH 0.015" (.38 MM) RADIUS UNLESS OTHERWISE NOTED. STANDARD TOLERANCES TO APPLY UNLESS OTHERWISE SPECIFIED.

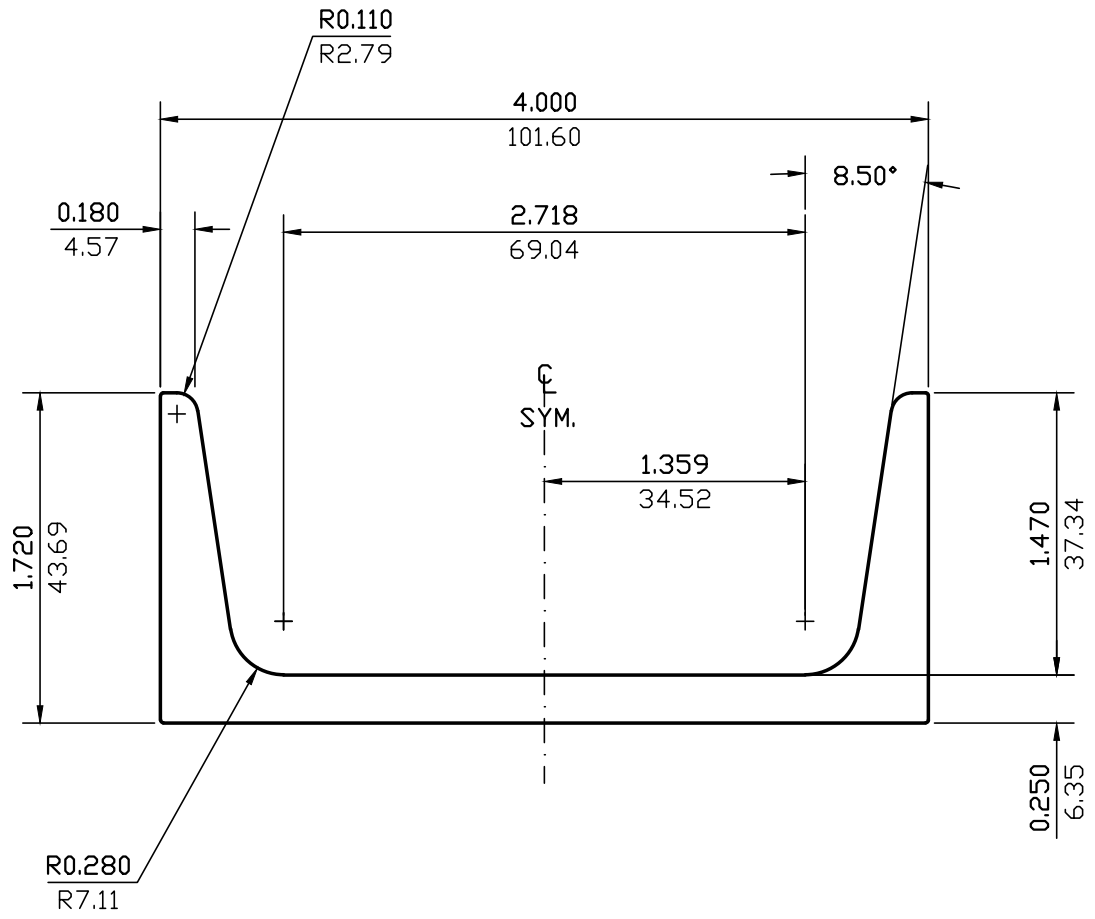

WALL THICKNESS AS SHOWN EXCEPT AS SHOWN

DATE	REV	DESCRIPTION	BY
EST.AREA	1.872	IN. ²	EST.AREA 1207.859
EST.WT.	2.247	LBS/FT.	EST.WT. 3.343
EST.PER.	13.739	IN.	EST.PER. 348.958
OUT PER.		IN.	OUT PER.
C.C.D.	4.354	IN.	C.C.D. 110.595
FACTOR	6	FINISH	M/F
		ALLOY & TEMP.	6063
CKD BY	SCALE	DWN BY	DATE
	1:1	C.P.	07/23/2001

CAN ART

85 PARKSHORE DRIVE
BRAMPTON, ONT L6T 5M1
TEL. NO. (905) 791-1464
FAX NO. (905) 791-9151
E-MAIL: canart@canart.com

ALUMINUM EXTRUSION INC.

THIS DRAWING IS NOT NECESSARILY A COPY OF YOUR ORIGINAL. PLEASE APPROVE DIMENSIONS AND TOLERANCES INDICATED. CAN ART ASSUMES NO RESPONSIBILITY EITHER TECHNICAL OR LEGAL FOR HAVING THIS SHAPE MADE. THE CUSTOMER AGREES TO FULLY PROTECT CAN ART ALUMINUM FROM CLAIMS OF OTHERS RESULTING FROM THIS SHAPE.

SIGNED: _____ DATE: _____