

NOTE: BREAK ALL CORNERS WITH 0.015" (.38 MM) RADIUS UNLESS OTHERWISE NOTED. STANDARD TOLERANCES TO APPLY UNLESS OTHERWISE SPECIFIED.

CUSTOMER	CAN ART STD.	DIE No.	ES05887	REV. No.	1
DESCRIPTION	CUSTOMER PART No.	QUOTE No.	PROPOSAL No.		
2.250 x 1.000 x 0.188 CHANNEL W/ INSIDE R.C.		08-0350-7	S-19219		

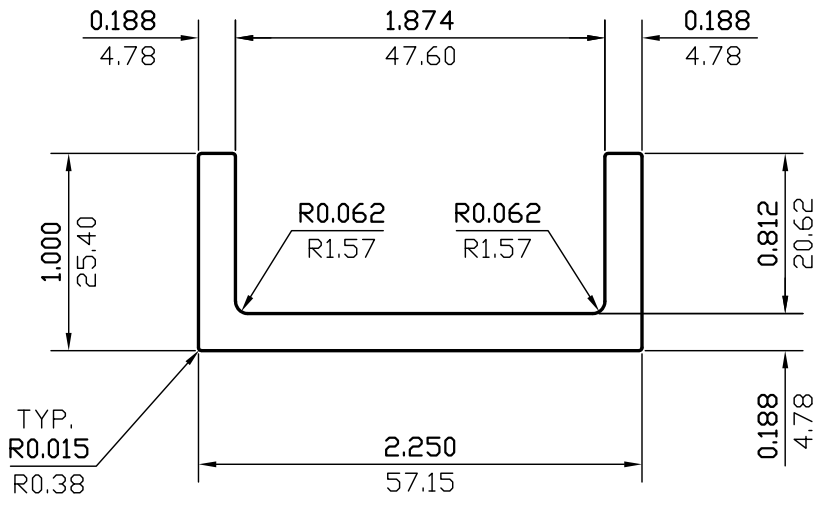

WALL THICKNESS 0.188(4.78) EXCEPT AS SHOWN

DATE	REV	DESCRIPTION	BY
03/21/23	1	REMOVED ALLDY	JASON
EST.AREA	0.730	IN. ²	EST.AREA 470.759
			MM. ²
EST.WT.	0.861	LBS/FT.	EST.WT. 1.281
			KG/M.
EST.PER.	8.032	IN.	EST.PER. 204.017
			MM.
OUT PER.		IN.	OUT PER.
			MM.
C.C.D.	2.450	IN.	C.C.D. 62.235
			MM.
FINISH	M/F		ALLOY
CKD BY	FACTOR 9	SCALE 1:1	DWN BY C.P. DATE 06/09/2008

CAN ART

85 PARKSHORE DRIVE
BRAMPTON, ONT L6T 5M1
TEL. NO. (905) 791-1464
FAX NO. (905) 791-9151
WEB: www.canart.com

ALUMINUM EXTRUSION INC.

THIS DRAWING IS NOT NECESSARILY A COPY OF YOUR ORIGINAL. PLEASE APPROVE DIMENSIONS AND TOLERANCES INDICATED. CAN ART ASSUMES NO RESPONSIBILITY EITHER TECHNICAL OR LEGAL FOR HAVING THIS SHAPE MADE. THE CUSTOMER AGREES TO FULLY PROTECT CAN ART ALUMINUM FROM CLAIMS OF OTHERS RESULTING FROM THIS SHAPE.

SIGNED: _____ DATE: _____