

CUSTOMER PART No.

CUSTOMER

CAN ART STD.

DIE No.

ES05623

DESCRIPTION

TEE 1" x 1" x .125"

PROPOSAL No.

S-8380

NOTE: BREAK ALL CORNERS WITH 0.015" (.38 MM) RADIUS UNLESS OTHERWISE NOTED. STANDARD TOLERANCES TO APPLY UNLESS OTHERWISE SPECIFIED.

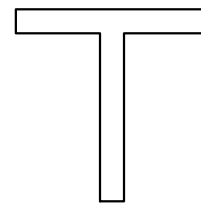
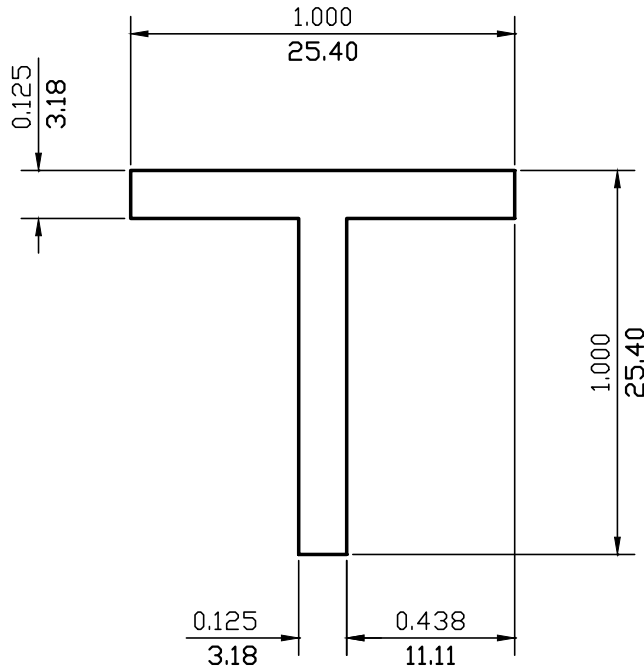

ACTUAL SIZE

WALL THICKNESS 0.125 (3.18) EXCEPT AS SHOWN

DATE	REV	DESCRIPTION		BY	
EST.AREA	0.234	IN. ²	EST.AREA	151.211	MM. ²
EST.WT.	0.277	LBS/FT.	EST.WT.	0.412	KG/M.
EST.PER.	4.000	IN.	EST.PER.	101.600	MM.
OUT PER.		IN.	OUT PER.		MM.
C.C.D.	1.254	IN.	C.C.D.	31.847	MM.
FACTOR	14	FINISH	M/F	ALLOY & TEMP.	6063-T5
CKD BY		SCALE	2:1	DWN BY	C.P.
				DATE	02/18/99

CAN ART

ALUMINUM EXTRUSION INC.

85 PARKSHORE DRIVE
BRAMPTON, ONT L6T 5M1
TEL. NO. (905) 791-1464
FAX NO. (905) 791-9151
E-MAIL: canart@canart.com

THIS DRAWING IS NOT NECESSARILY A COPY OF YOUR ORIGINAL. PLEASE APPROVE DIMENSIONS AND TOLERANCES INDICATED. CAN ART ASSUMES NO RESPONSIBILITY EITHER TECHNICAL OR LEGAL FOR HAVING THIS SHAPE MADE. THE CUSTOMER AGREES TO FULLY PROTECT CAN ART ALUMINUM FROM CLAIMS OF OTHERS RESULTING FROM THIS SHAPE.

SIGNED: _____ DATE: _____