

CUSTOMER

**CAN ART STD.**

DIE No.

**EH61843**

REV. No.

**1**

DESCRIPTION

2.500 x 0.187 SQ. TUBE w/ ROUND CORNERS

CUSTOMER PART No.

QUOTE No.

08-0164-1

PROPOSAL No.

H-18867

NOTE: BREAK ALL CORNERS WITH 0.015" (.38 MM) RADIUS UNLESS OTHERWISE NOTED. STANDARD TOLERANCES TO APPLY UNLESS OTHERWISE SPECIFIED.

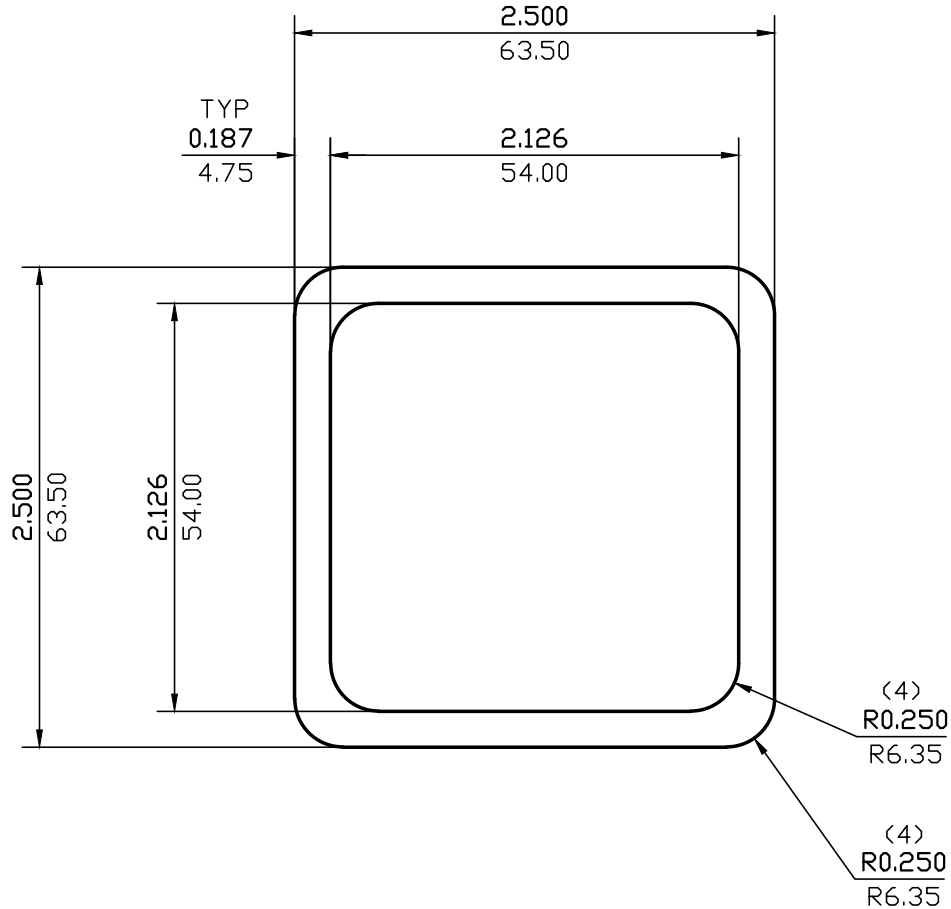

WALL THICKNESS 0.187 (4.75) EXCEPT AS SHOWN

DATE	REV	DESCRIPTION		BY	
EST.AREA	1.730	IN. <sup>2</sup>	EST.AREA	1116.216	MM. <sup>2</sup>
EST.WT.	2.042	LBS/FT.	EST.WT.	3.038	KG/M.
EST.PER.	17.646	IN.	EST.PER.	448.198	MM.
OUT PER.	9.571	IN.	OUT PER.	243.1	MM.
C.C.D.	3.328	IN.	C.C.D.	84.542	MM.
FINISH	M/F		ALLOY	6061-T6	
CKD BY	FACTOR 9	SCALE 1:1	DWN BY P.M.	DATE	03/18/2008

**CAN ART**

85 PARKSHORE DRIVE  
BRAMPTON, ONT L6T 5M1  
TEL. NO. (905) 791-1464  
FAX NO. (905) 791-9151  
WEB: www.canart.com

ALUMINUM EXTRUSION INC.

THIS DRAWING IS NOT NECESSARILY A COPY OF YOUR ORIGINAL. PLEASE APPROVE DIMENSIONS AND TOLERANCES INDICATED. CAN ART ASSUMES NO RESPONSIBILITY EITHER TECHNICAL OR LEGAL FOR HAVING THIS SHAPE MADE. THE CUSTOMER AGREES TO FULLY PROTECT CAN ART ALUMINUM FROM CLAIMS OF OTHERS RESULTING FROM THIS SHAPE.

SIGNED: \_\_\_\_\_ DATE: \_\_\_\_\_