

NOTE: BREAK ALL CORNERS WITH 0.015" (.38 MM) RADIUS UNLESS OTHERWISE NOTED. STANDARD TOLERANCES TO APPLY UNLESS OTHERWISE SPECIFIED.

CUSTOMER	CAN ART STD.	DIE No. EH05983	REV. No. 1
DESCRIPTION 1.750 x 0.065 THK. ROUND TUBE	CUSTOMER PART No.	QUOTE No. 11-0431-1	PROPOSAL No. H-24324

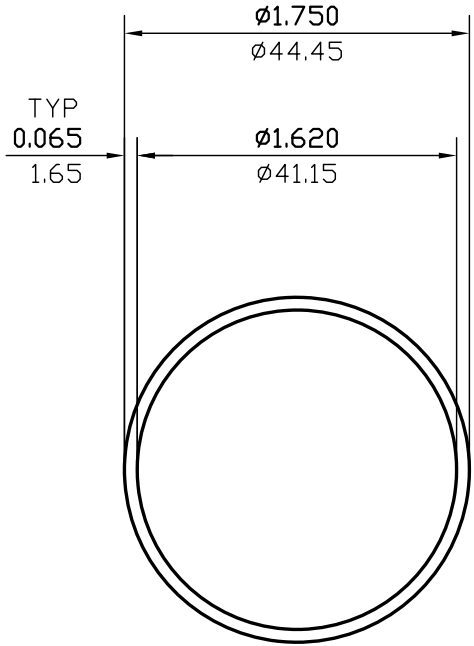

WALL THICKNESS 0.065 (1.65) EXCEPT AS SHOWN

DATE	REV	DESCRIPTION	BY
03/10/23	1	REMOVED ALLOY	JASON
EST.AREA	0.344	IN. ²	EST.AREA 221.990
			MM. ²
EST.WT.	0.406	LBS/FT.	EST.WT. 0.604
			KG/M.
EST.PER.	10.587	IN.	EST.PER. 268.914
			MM.
OUT PER.	5.498	IN.	OUT PER. 139.6
			MM.
C.C.D.	1.750	IN.	C.C.D. 44.450
			MM.
FINISH	M/F		ALLOY
CKD BY	FACTOR 26	SCALE 1:1	DWN BY P.M. DATE 05/18/2011

CAN ART

ALUMINUM EXTRUSION INC.

85 PARKSHORE DRIVE
BRAMPTON, ONT L6T 5M1
TEL. NO. (905) 791-1464
FAX NO. (905) 791-9151
WEB: www.canart.com

THIS DRAWING IS NOT NECESSARILY A COPY OF YOUR ORIGINAL. PLEASE APPROVE DIMENSIONS AND TOLERANCES INDICATED. CAN ART ASSUMES NO RESPONSIBILITY EITHER TECHNICAL OR LEGAL FOR HAVING THIS SHAPE MADE. THE CUSTOMER AGREES TO FULLY PROTECT CAN ART ALUMINUM FROM CLAIMS OF OTHERS RESULTING FROM THIS SHAPE.

SIGNED: _____ DATE: _____