

NOTE: BREAK ALL CORNERS WITH 0.015" (.38 MM) RADIUS UNLESS OTHERWISE SPECIFIED. STANDARD TOLERANCES TO APPLY UNLESS OTHERWISE SPECIFIED.

CUSTOMER	CAN ART STD	DIE No.	EH05807	REV. No.	1
DESCRIPTION	3.250 x 3.060 x 0.095 ROUND TUBE	CUSTOMER PART No.	PROPOSAL No. H-52985		

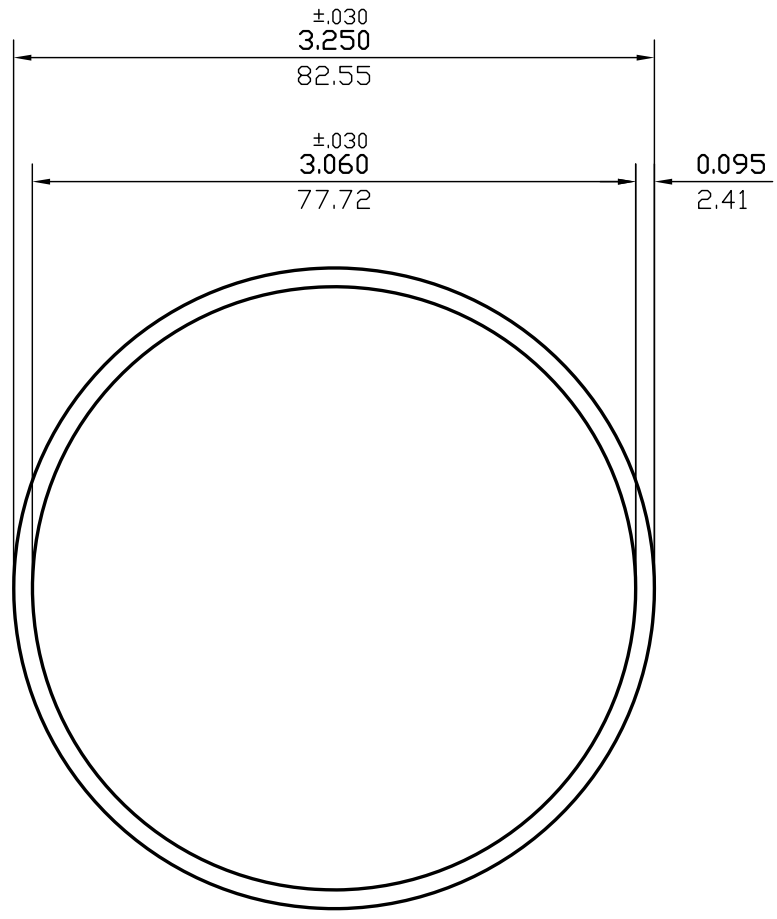

WALL THICKNESS 0.095 (2.41) EXCEPT AS SHOWN

DATE	REV	DESCRIPTION	BY
03/10/23	1	REMOVED ALLOY	JASON
EST. AREA		0.942 IN. ²	EST. AREA 607.496 MM. ²
EST. WT.		1.111 LBS/FT.	EST. WT. 1.654 KG/M.
EST. PER.		19.823 IN.	EST. PER. 503.516 MM.
OUT PER.		10.210 IN.	OUT PER. 259.3 MM.
C.C.D.		3.250 IN.	C.C.D. 82.550 MM.
FINISH		M/F	ALLOY
CKD BY	FACTOR 18	SCALE 1:1	DWN BY J.C. DATE 01/18/2005

CAN ART

428 JUTRAS DRIVE S.
WINDSOR, ON N8N 5C5
TEL. NO. (519) 727-4399
FAX NO. (519) 727-6434
WEB: www.canart.com

ALUMINUM EXTRUSION INC.

THIS DRAWING IS NOT NECESSARILY A COPY OF YOUR ORIGINAL. PLEASE APPROVE DIMENSIONS AND TOLERANCES INDICATED. CAN ART ASSUMES NO RESPONSIBILITY EITHER TECHNICAL OR LEGAL FOR HAVING THIS SHAPE MADE. THE CUSTOMER AGREES TO FULLY PROTECT CAN ART ALUMINUM FROM CLAIMS OF OTHERS RESULTING FROM THIS SHAPE.

SIGNED: _____ DATE: _____