

CUSTOMER PART No.

CUSTOMER

CAN ART STD.

DIE No.

EH05565

DESCRIPTION

1 1/8" x 1 1/8" x 0.074" THK. SQ. TUBE

PROPOSAL No.

H-6577

NOTE: BREAK ALL CORNERS WITH 0.015" (.38 MM) RADIUS UNLESS OTHERWISE NOTED. STANDARD TOLERANCES TO APPLY UNLESS OTHERWISE SPECIFIED.

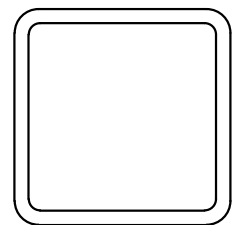
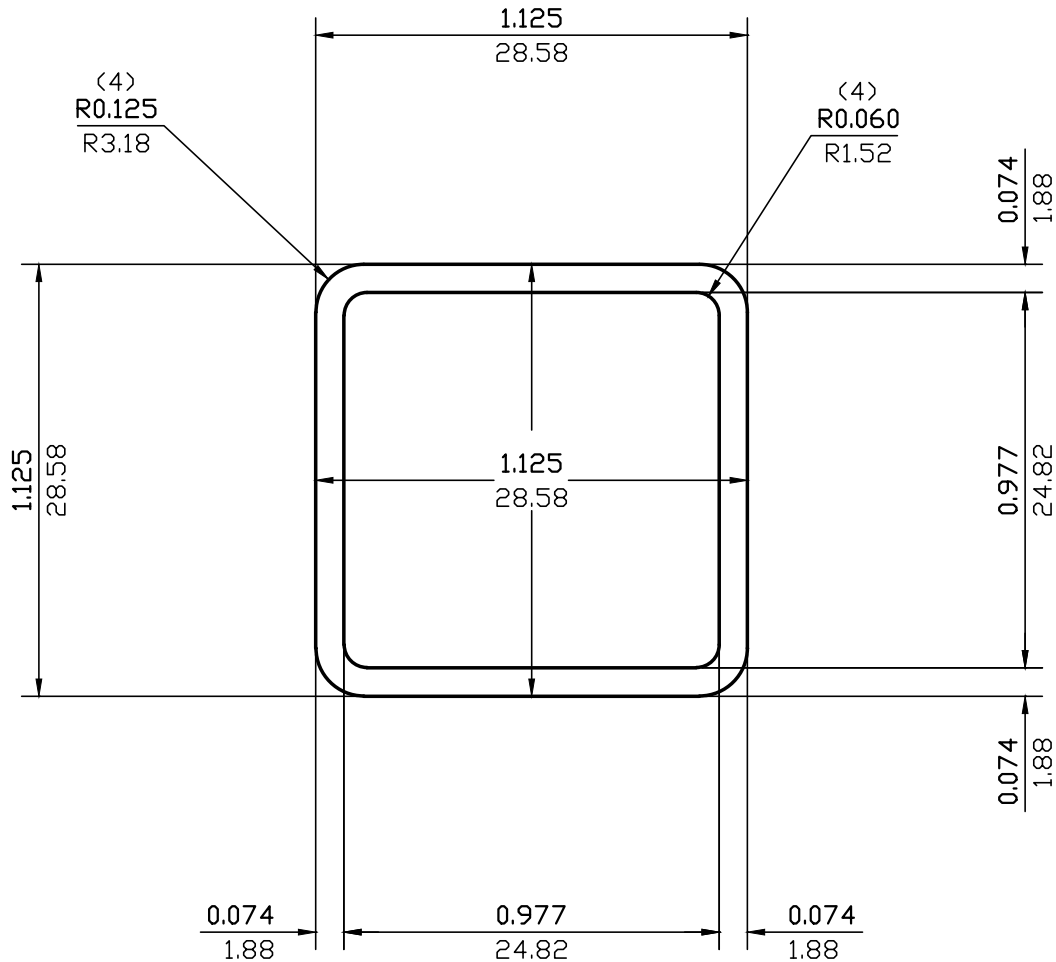

ACTUAL SIZE

WALL THICKNESS 0.074 (1.88) EXCEPT AS SHOWN

DATE	REV	DESCRIPTION		BY	
EST.AREA	0.301	IN. ²	EST.AREA	194	MM. ²
EST.WT.	0.361	LBS./FT.	EST.WT.	0.537	KG/M.
EST.PER.	8.090	IN.	EST.PER.	205.5	MM.
OUT PER.	4.285	IN.	OUT PER.	108.8	MM.
C.C.D.	1.487	IN.	C.C.D.	38	MM.
FACTOR	23	FINISH	M/F	ALLOY & TEMP.	6063
CKD BY		SCALE	2:1	DWN BY	C.P.
				DATE	06/12/97

CAN ART

ALUMINUM EXTRUSION INC.

85 PARKSHORE DRIVE
BRAMPTON, ONT L6T 5M1
TEL. NO. (905) 791-1464
FAX NO. (905) 791-9151
E-MAIL: canart@canart.com

THIS DRAWING IS NOT NECESSARILY A COPY OF YOUR ORIGINAL. PLEASE APPROVE DIMENSIONS AND TOLERANCES INDICATED. CAN ART ASSUMES NO RESPONSIBILITY EITHER TECHNICAL OR LEGAL FOR HAVING THIS SHAPE MADE. THE CUSTOMER AGREES TO FULLY PROTECT CAN ART ALUMINUM FROM CLAIMS OF OTHERS RESULTING FROM THIS SHAPE.

SIGNED: _____ DATE: _____