

CUSTOMER PART No.	CUSTOMER <b>CAN ART STD.</b>	DIE No. <b>EH05420</b>
-------------------	---------------------------------	---------------------------

DESCRIPTION <b>1 1/2" x 1 1/2" x 0.120" THK. SQ. TUBE</b>	PROPOSAL No. <b>H-3159</b>
--	----------------------------

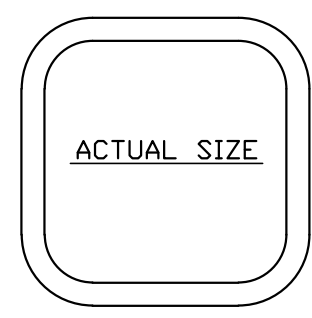
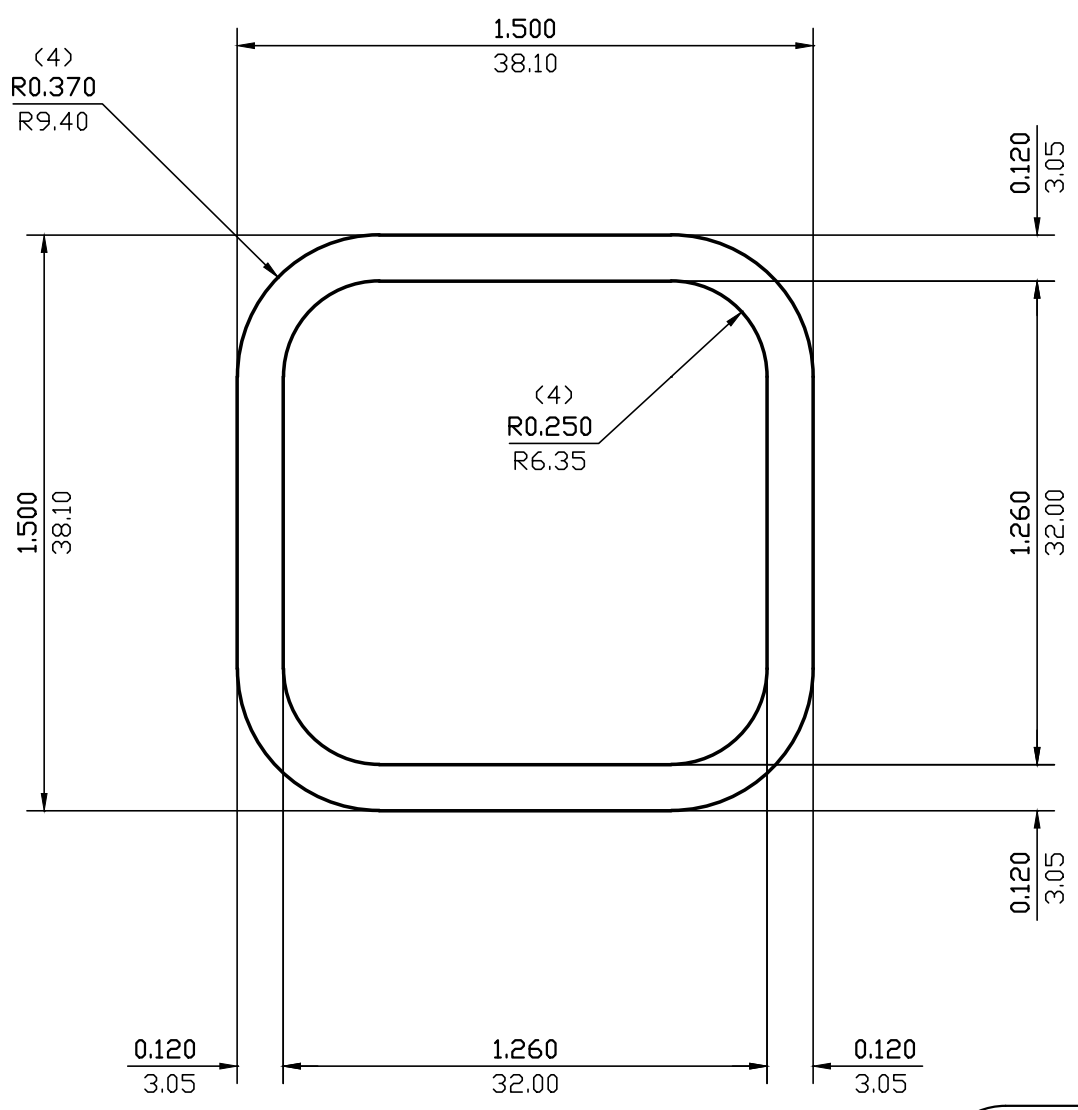

NOTE: BREAK ALL CORNERS WITH 0.015" (.38 MM) RADIUS UNLESS OTHERWISE NOTED. STANDARD TOLERANCES TO APPLY UNLESS OTHERWISE SPECIFIED.

WALL THICKNESS **0.120 (3.05)** EXCEPT AS SHOWN

DATE	REV	DESCRIPTION		BY			
EST.AREA	<b>0.599</b>	IN. <sup>2</sup>	EST.AREA	<b>386</b>	MM. <sup>2</sup>		
EST.WT.	<b>0.706</b>	LBS./FT.	EST.WT.	<b>1.051</b>	KG/M.		
EST.PER.	<b>9.976</b>	IN.	EST.PER.	<b>253.4</b>	MM.		
OUT PER.	<b>5.365</b>	IN.	OUT PER.	<b>136.3</b>	MM.		
C.C.D.	<b>1.815</b>	IN.	C.C.D.	<b>46</b>	MM.		
FACTOR	<b>14</b>	FINISH	<b>M/F</b>		ALLOY & TEMP.	<b>6061</b>	
CKD BY		SCALE	<b>2:1</b>	DWN BY	<b>C.P.</b>	DATE	<b>08/03/93</b>

# CAN ART

ALUMINUM EXTRUSION INC.

85 PARKSHORE DRIVE  
BRAMPTON, ONT L6T 5M1  
TEL. NO. (905) 791-1464  
FAX NO. (905) 791-9151  
E-MAIL: canart@canart.com

THIS DRAWING IS NOT NECESSARILY A COPY OF YOUR ORIGINAL. PLEASE APPROVE DIMENSIONS AND TOLERANCES INDICATED. CAN ART ASSUMES NO RESPONSIBILITY EITHER TECHNICAL OR LEGAL FOR HAVING THIS SHAPE MADE. THE CUSTOMER AGREES TO FULLY PROTECT CAN ART ALUMINUM FROM CLAIMS OF OTHERS RESULTING FROM THIS SHAPE.

SIGNED: \_\_\_\_\_ DATE: \_\_\_\_\_