

CUSTOMER PART No.

CUSTOMER

CAN ART STD.

DIE No.

EH05418

DESCRIPTION

2" x 2" x 0.120" THK. SQ. TUBE

PROPOSAL No.

H-3077

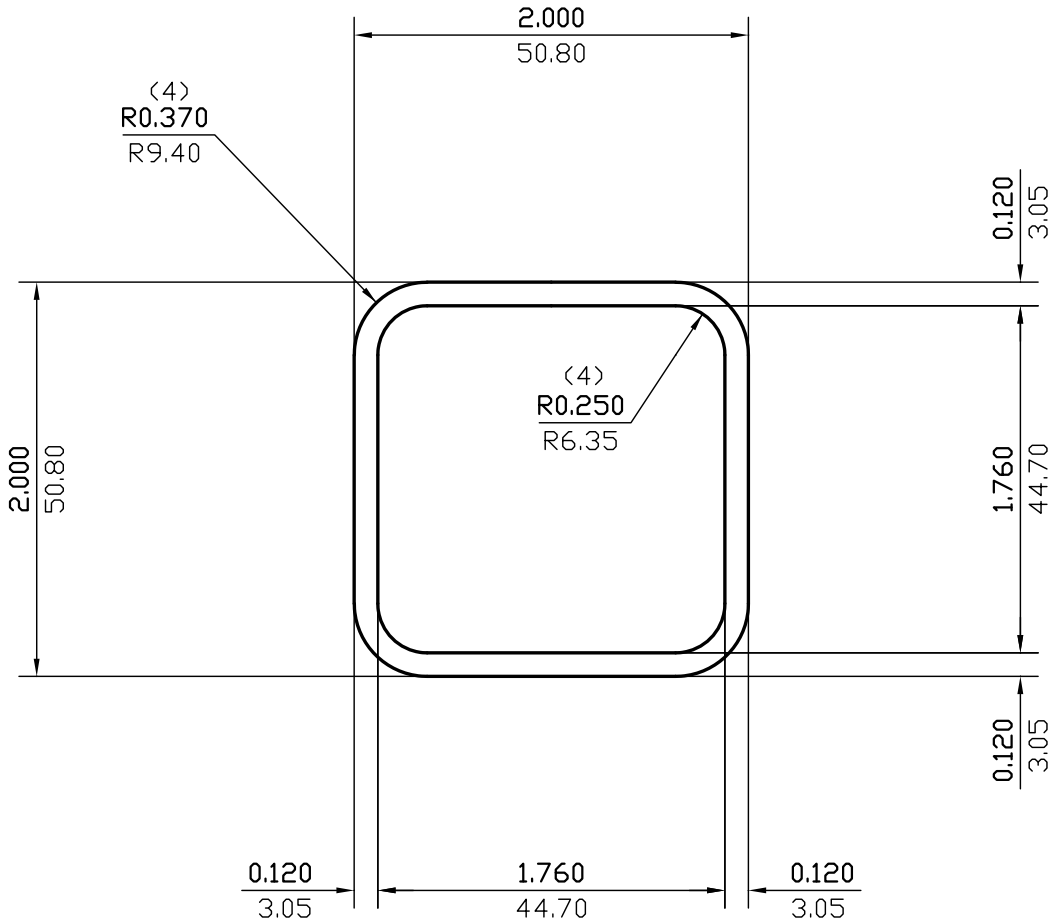

NOTE: BREAK ALL CORNERS WITH 0.015" (.38 MM) RADIUS UNLESS OTHERWISE NOTED. STANDARD TOLERANCES TO APPLY UNLESS OTHERWISE SPECIFIED.

WALL THICKNESS 0.120 (3.05) EXCEPT AS SHOWN

DATE	REV	DESCRIPTION	BY		
03/13/23	2	REMOVED ALLOY	JASON		
08/06/99	1	REDRAWN	P.M.		
EST.AREA	0.839	IN. ²	EST.AREA	541	MM. ²
EST.WT.	0.989	LBS/FT.	EST.WT.	1.473	KG/M.
EST.PER.	13.976	IN.	EST.PER.	355.0	MM.
OUT PER.	7.365	IN.	OUT PER.	187.1	MM.
C.C.D.	2.522	IN.	C.C.D.	64	MM.
FACTOR	14	FINISH	M/F	ALLOY & TEMP.	
CKD BY		SCALE	1:1	DWN BY	C.P.
				DATE	06/30/93

CAN ART

ALUMINUM EXTRUSION INC.

85 PARKSHORE DRIVE
BRAMPTON, ONT L6T 5M1
TEL. NO. (905) 791-1464
FAX NO. (905) 791-9151
E-MAIL: canart@canart.com

THIS DRAWING IS NOT NECESSARILY A COPY OF YOUR ORIGINAL. PLEASE APPROVE DIMENSIONS AND TOLERANCES INDICATED. CAN ART ASSUMES NO RESPONSIBILITY EITHER TECHNICAL OR LEGAL FOR HAVING THIS SHAPE MADE. THE CUSTOMER AGREES TO FULLY PROTECT CAN ART ALUMINUM FROM CLAIMS OF OTHERS RESULTING FROM THIS SHAPE.

SIGNED: _____ DATE: _____