

CUSTOMER PART No.	CUSTOMER CAN ART STD.	DIE No. EH05407
DESCRIPTION	1" x 1" x 0.093" THK. SQ. TUBE	PROPOSAL No. H-2694

NOTE: BREAK ALL CORNERS WITH 0.015" (.38 MM) RADIUS UNLESS OTHERWISE NOTED. STANDARD TOLERANCES TO APPLY UNLESS OTHERWISE SPECIFIED.

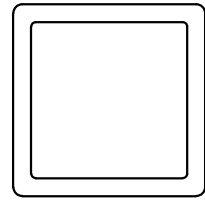
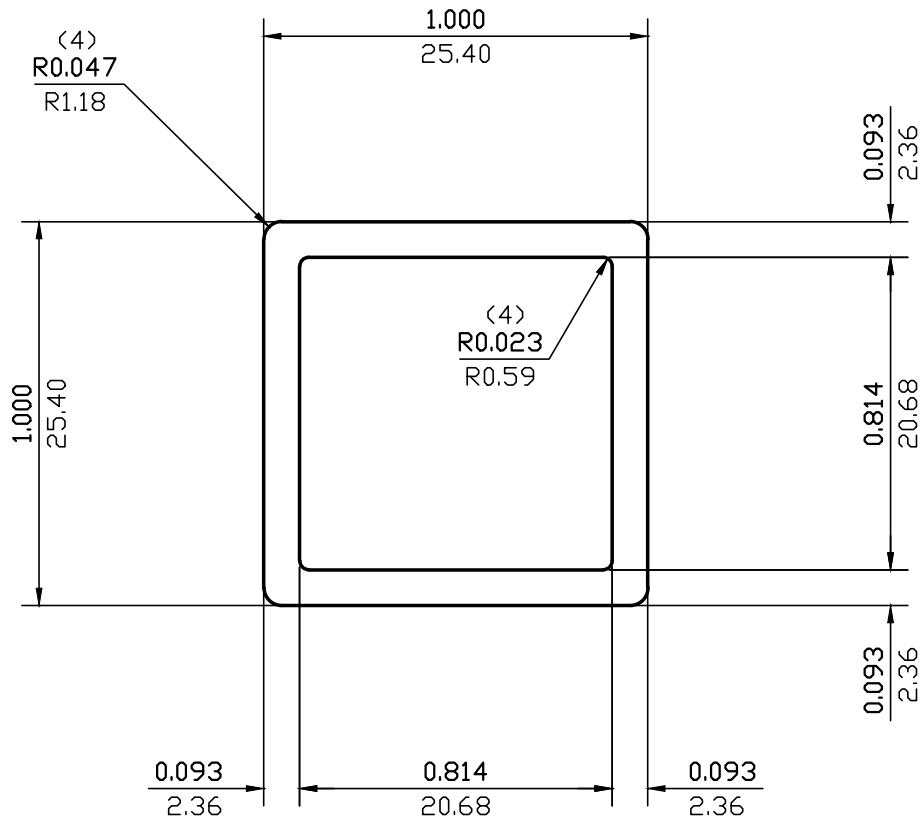

ACTUAL SIZE

WALL THICKNESS **0.093 (2.36)** EXCEPT AS SHOWN

DATE	REV	DESCRIPTION	BY
EST.AREA	0.336	IN. ²	EST.AREA 217 MM. ²
EST.WT.	0.396	LBS./FT.	EST.WT. 0.590 KG/M.
EST.PER.	7.136	IN.	EST.PER. 181.3 MM.
OUT PER.	3.920	IN.	OUT PER. 99.6 MM.
C.C.D.	1.376	IN.	C.C.D. 35 MM.
FACTOR 18	FINISH M/F	ALLOY & TEMP. 6063	
CKD BY	SCALE 2:1	DWN BY C.P.	DATE 11/24/92

CAN ART

85 PARKSHORE DRIVE
BRAMPTON, ONT L6T 5M1
TEL. NO. (905) 791-1464
FAX NO. (905) 791-9151
E-MAIL: canart@canart.com

ALUMINUM EXTRUSION INC.

THIS DRAWING IS NOT NECESSARILY A COPY OF YOUR ORIGINAL. PLEASE APPROVE DIMENSIONS AND TOLERANCES INDICATED. CAN ART ASSUMES NO RESPONSIBILITY EITHER TECHNICAL OR LEGAL FOR HAVING THIS SHAPE MADE. THE CUSTOMER AGREES TO FULLY PROTECT CAN ART ALUMINUM FROM CLAIMS OF OTHERS RESULTING FROM THIS SHAPE.

SIGNED: _____ DATE: _____