

CUSTOMER

CAN ART STD.

DIE No.

EHO4041

REV. No.

1

DESCRIPTION

2.000 x 0.187 THK. SQ. TUBE w/ ROUNDED CORNERS

CUSTOMER PART No.

QUOTE No.

17-0166-1

PROPOSAL No.

H-35108

NOTE: BREAK ALL CORNERS WITH 0.015" (.38 MM) RADIUS UNLESS OTHERWISE NOTED. STANDARD TOLERANCES TO APPLY UNLESS OTHERWISE SPECIFIED.

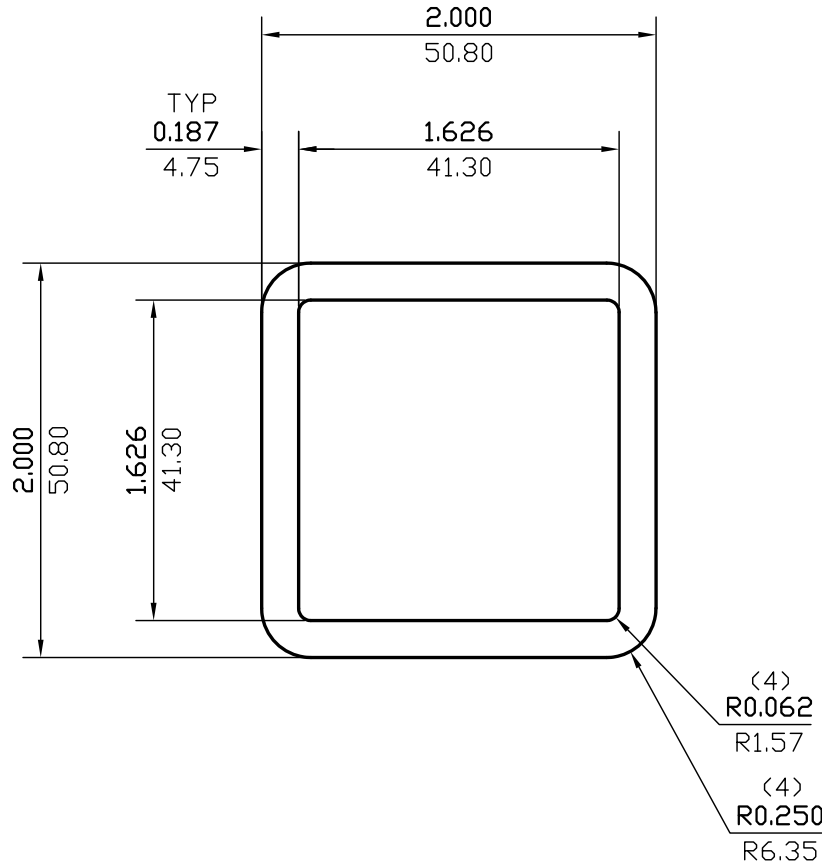

WALL THICKNESS 0.187 (4.75) EXCEPT AS SHOWN

DATE	REV	DESCRIPTION	BY
03/13/23	1	REMOVED ALLOY	JASON
EST.AREA	1.306	IN. ²	EST.AREA 842.439
			MM. ²
EST.WT.	1.541	LBS/FT.	EST.WT. 2.293
			KG/M.
EST.PER.	13.968	IN.	EST.PER. 354.796
			MM.
OUT PER.	7.571	IN.	OUT PER. 192.3
			MM.
C.C.D.	2.621	IN.	C.C.D. 66.582
			MM.
FINISH	M/F		ALLOY
CKD BY	FACTOR 9	SCALE 1:1	DWN BY P.M. DATE 02/20/2017

CAN ART

ALUMINUM EXTRUSION L.P.

85 PARKSHORE DRIVE
BRAMPTON, ONT L6T 5M1
TEL. NO. (905) 791-1464
FAX NO. (905) 791-9151
WEB: www.canart.com

THIS DRAWING IS NOT NECESSARILY A COPY OF YOUR ORIGINAL. PLEASE APPROVE DIMENSIONS AND TOLERANCES INDICATED. CAN ART ASSUMES NO RESPONSIBILITY EITHER TECHNICAL OR LEGAL FOR HAVING THIS SHAPE MADE. THE CUSTOMER AGREES TO FULLY PROTECT CAN ART ALUMINUM FROM CLAIMS OF OTHERS RESULTING FROM THIS SHAPE.

SIGNED: _____ DATE: _____