

CUSTOMER

CAN ART STD.

DIE No.

EH04007

REV. No.

2

DESCRIPTION

0.750 x 0.125 THK. ROUND TUBE

CUSTOMER PART No.

QUOTE No.

12-1089-1

PROPOSAL No.

H-27076

NOTE: BREAK ALL CORNERS WITH 0.015" (.38 MM) RADIUS UNLESS OTHERWISE SPECIFIED. STANDARD TOLERANCES TO APPLY UNLESS OTHERWISE SPECIFIED.

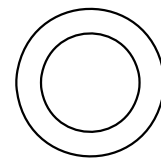
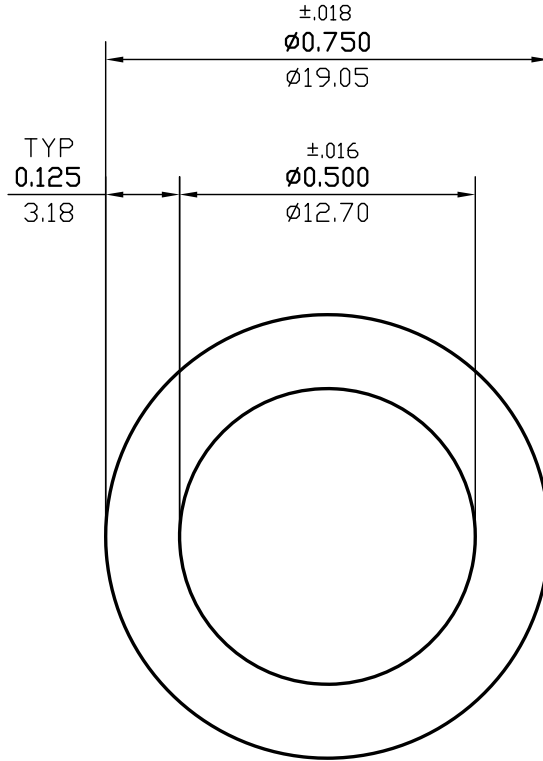

ACTUAL SIZE

WALL THICKNESS 0.125 (3.17) EXCEPT AS SHOWN

DATE	REV	DESCRIPTION	BY
03/10/23	2	REMOVED ALLOY	JASON
01/20/23	1	ADDED TOLERANCES.	PAUL
EST.AREA	0.245	IN. ²	EST.AREA 158.347
			MM. ²
EST.WT.	0.290	LBS/FT.	EST.WT. 0.431
			KG/M.
EST.PER.	3.927	IN.	EST.PER. 99.746
			MM.
OUT PER.	2.356	IN.	OUT PER. 59.8
			MM.
C.C.D.	0.750	IN.	C.C.D. 19.050
			MM.
FINISH	M/F		ALLOY
CKD BY	FACTOR 14	SCALE 3:1	DWN BY P.M. DATE 11/16/2012

CAN ART

ALUMINUM EXTRUSION INC.

85 PARKSHORE DRIVE
BRAMPTON, ONT L6T 5M1
TEL. NO. (905) 791-1464
FAX NO. (905) 791-9151
WEB: www.canart.com

THIS DRAWING IS NOT NECESSARILY A COPY OF YOUR ORIGINAL. PLEASE APPROVE DIMENSIONS AND TOLERANCES INDICATED. CAN ART ASSUMES NO RESPONSIBILITY EITHER TECHNICAL OR LEGAL FOR HAVING THIS SHAPE MADE. THE CUSTOMER AGREES TO FULLY PROTECT CAN ART ALUMINUM FROM CLAIMS OF OTHERS RESULTING FROM THIS SHAPE.

SIGNED: _____ DATE: _____