

NOTE: BREAK ALL CORNERS WITH 0.015" (.38 MM) RADIUS UNLESS OTHERWISE NOTED. STANDARD TOLERANCES TO APPLY UNLESS OTHERWISE SPECIFIED.

CUSTOMER <b>CAN ART OPEN</b>		DIE No. <b>ES63479</b>	REV. No. <b>1</b>
DESCRIPTION <b>GABLE EXTRUSION</b>	CUSTOMER PART No.	QUOTE No. <b>L12-0342-7</b>	PROPOSAL No. <b>S-61835</b>

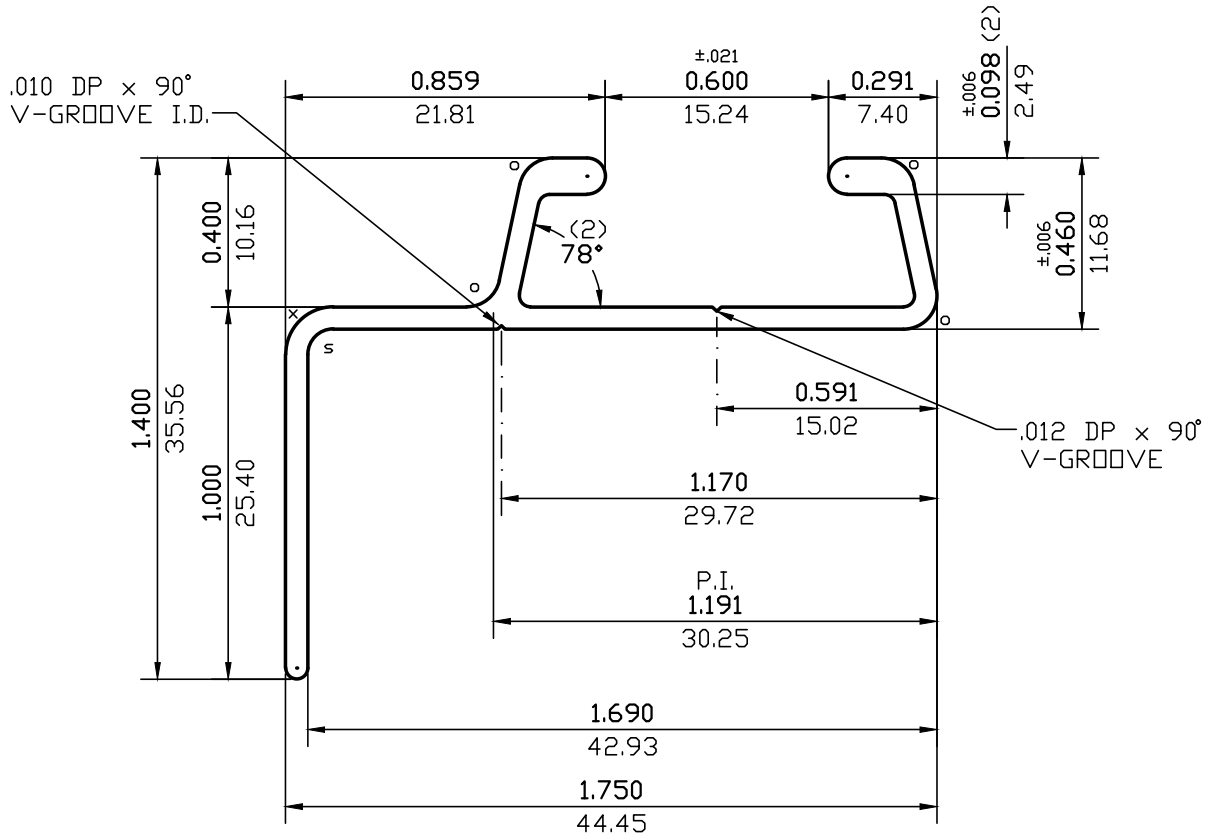

- (·) = FULL R. (3)
- (s) = R0.068(R1.73) (1)
- (o) = R0.090(R2.29) (4)
- (x) = R0.128(R3.25) (1)
- UNMARKED RAD. = R0.030(R0.76)

\*\*\* = SHADOW LINE MAY OCCUR.

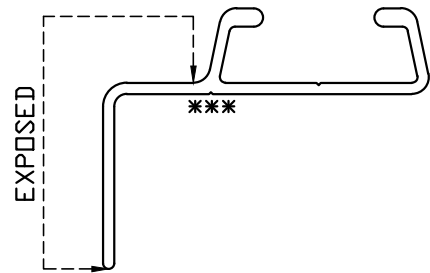

WALL THICKNESS 0.060 (1.52) EXCEPT AS SHOWN

DATE	REV	DESCRIPTION	BY
09/18/2015	1	CHANGED TO CAN ART OPEN	J.T.
EST.AREA	0.235	IN. <sup>2</sup>	EST.AREA 151.776
EST.WT.	0.282	LBS/FT.	EST.WT. 0.420
EST.PER.	7.453	IN.	EST.PER. 189.301
OUT PER.		IN.	OUT PER.
C.C.D.	2.146	IN.	C.C.D. 54.509
FINISH	M/F	ALLOY	6005A-T61
CKD BY	FACTOR 26	SCALE 2:1	DWN BY G.W. DATE 05/10/2012

# CAN ART

ALUMINUM EXTRUSION INC.

428 JUTRAS DRIVE S.  
WINDSOR, ON N8N 5C5  
TEL. NO. (519) 727-4399  
FAX NO. (519) 727-6434  
WEB: www.canart.com

THIS DRAWING IS NOT NECESSARILY A COPY OF YOUR ORIGINAL. PLEASE APPROVE DIMENSIONS AND TOLERANCES INDICATED. CAN ART ASSUMES NO RESPONSIBILITY EITHER TECHNICAL OR LEGAL FOR HAVING THIS SHAPE MADE. THE CUSTOMER AGREES TO FULLY PROTECT CAN ART ALUMINUM FROM CLAIMS OF OTHERS RESULTING FROM THIS SHAPE.

SIGNED: \_\_\_\_\_ DATE: \_\_\_\_\_