

NOTE: BREAK ALL CORNERS WITH 0.015" (.38 MM) RADIUS UNLESS OTHERWISE NOTED. STANDARD TOLERANCES TO APPLY UNLESS OTHERWISE SPECIFIED.

CUSTOMER	CAN ART OPEN	DIE No.	ES13188	REV. No.	0
DESCRIPTION	SILL	CUSTOMER PART No.		PROPOSAL No.	S-14085

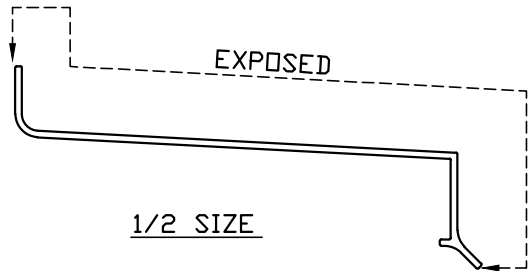
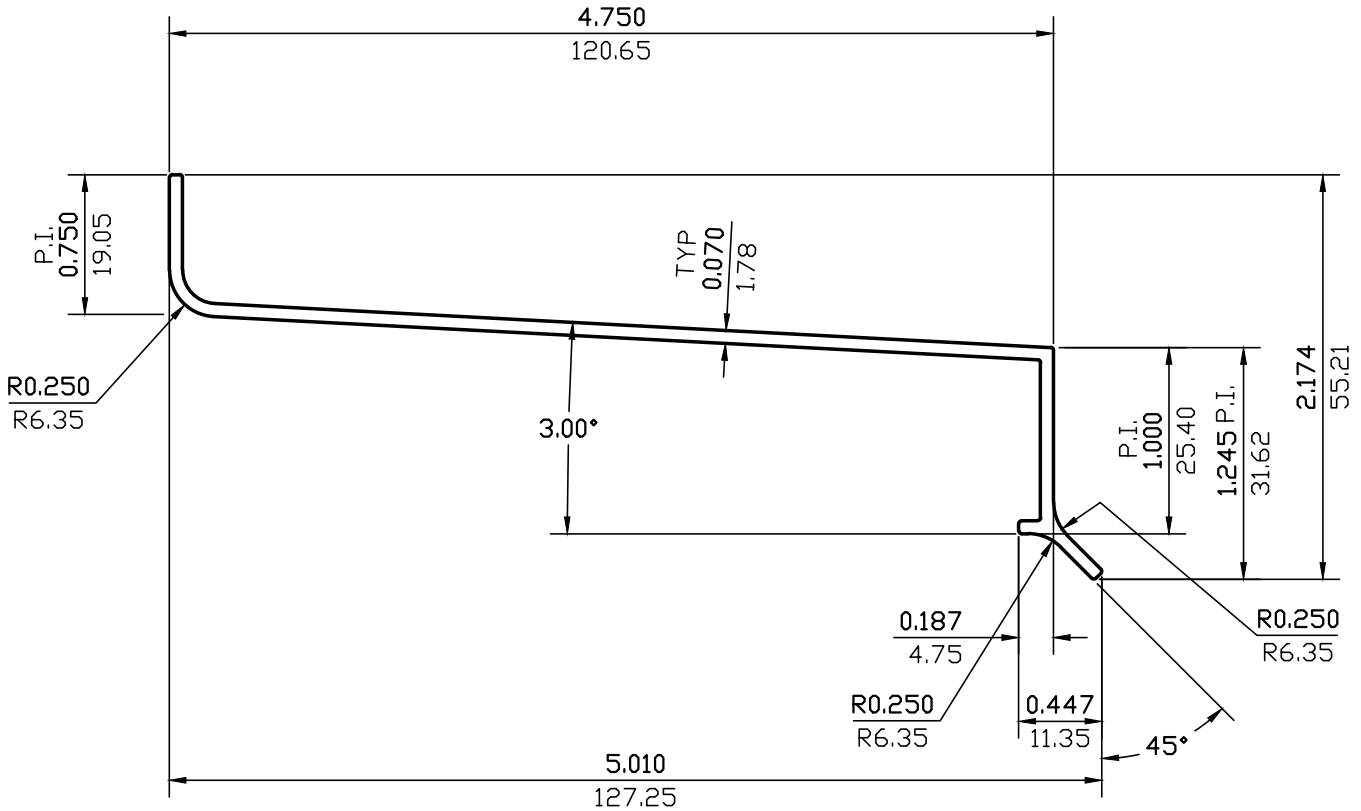

WALL THICKNESS 0.070 (1.78) EXCEPT AS SHOWN

DATE	REV	DESCRIPTION	BY	
EST.AREA	0.475	IN. ²	EST.AREA 306.644	MM. ²
EST.WT.	0.561	LBS/FT.	EST.WT. 0.835	KG/M.
EST.PER.	13.575	IN.	EST.PER. 344.798	MM.
OUT PER.		IN.	OUT PER.	MM.
C.C.D.	5.438	IN.	C.C.D. 138.124	MM.
FINISH	ANODIZE		ALLOY	6063
CKD BY	FACTOR 24	SCALE 1:1	DWN BY P.M.	DATE 11/10/2003

CAN ART

ALUMINUM EXTRUSION INC.

85 PARKSHORE DRIVE
BRAMPTON, ONT L6T 5M1
TEL. NO. (905) 791-1464
FAX NO. (905) 791-9151
WEB: www.canart.com

THIS DRAWING IS NOT NECESSARILY A COPY OF YOUR ORIGINAL. PLEASE APPROVE DIMENSIONS AND TOLERANCES INDICATED. CAN ART ASSUMES NO RESPONSIBILITY EITHER TECHNICAL OR LEGAL FOR HAVING THIS SHAPE MADE. THE CUSTOMER AGREES TO FULLY PROTECT CAN ART ALUMINUM FROM CLAIMS OF OTHERS RESULTING FROM THIS SHAPE.

SIGNED: _____ DATE: _____