

NOTE: BREAK ALL CORNERS WITH 0.015" (.38 MM) RADIUS UNLESS OTHERWISE NOTED. STANDARD TOLERANCES TO APPLY UNLESS OTHERWISE SPECIFIED.

CUSTOMER PART No.	CUSTOMER CAN ART OPEN	DIE No. ES12233
DESCRIPTION WIRELOCK		PROPOSAL No. S-11913

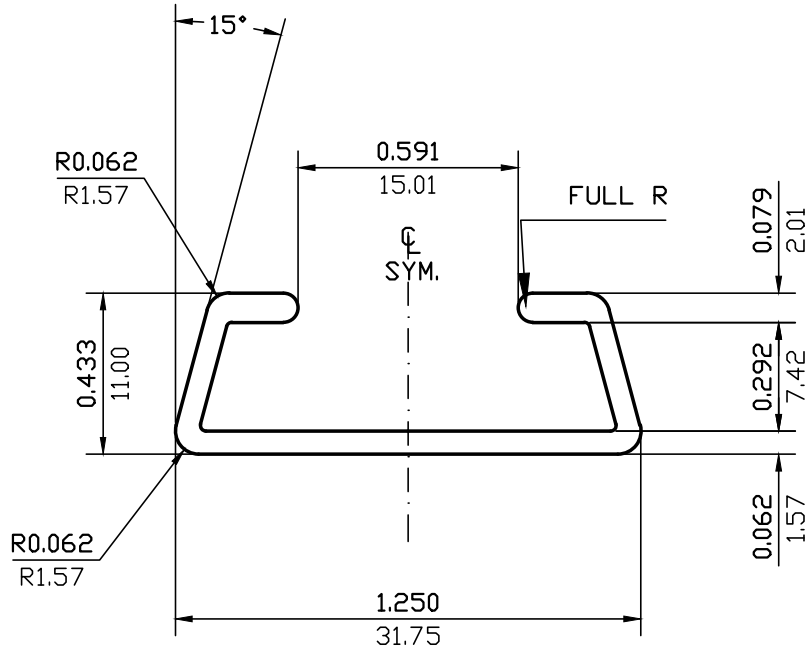

ACTUAL SIZE

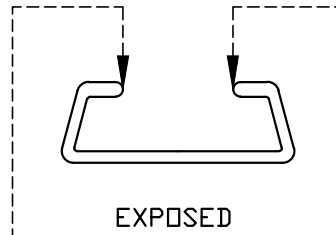

WALL THICKNESS 0.062(1.57) EXCEPT AS SHOWN

DATE	REV	DESCRIPTION	BY
EST.AREA	0.150	IN. ²	EST.AREA 96.583
EST.WT.	0.177	LBS/FT.	EST.WT. 0.263
EST.PER.	4.694	IN.	EST.PER. 119.230
OUT PER.		IN.	OUT PER.
C.C.D.	1.251	IN.	C.C.D. 31.767
FACTOR	27	FINISH	M/F
ALLOY & TEMP.	6005A		
CKD BY	SCALE	DWN BY	DATE
	2:1	C.P.	01/28/2002

CAN ART

ALUMINUM EXTRUSION INC.

85 PARKSHORE DRIVE
BRAMPTON, ONT L6T 5M1
TEL. NO. (905) 791-1464
FAX NO. (905) 791-9151
E-MAIL: canart@canart.com

THIS DRAWING IS NOT NECESSARILY A COPY OF YOUR ORIGINAL. PLEASE APPROVE DIMENSIONS AND TOLERANCES INDICATED. CAN ART ASSUMES NO RESPONSIBILITY EITHER TECHNICAL OR LEGAL FOR HAVING THIS SHAPE MADE. THE CUSTOMER AGREES TO FULLY PROTECT CAN ART ALUMINUM FROM CLAIMS OF OTHERS RESULTING FROM THIS SHAPE.

SIGNED: _____ DATE: _____