

CUSTOMER PART No.

CUSTOMER

# CAN ART OPEN

DIE No.

EH60607

DESCRIPTION

TUBE W/ FLANGE

PROPOSAL No.

H-51083

NOTE: BREAK ALL CORNERS WITH 0.015" (.38 MM) RADIUS UNLESS OTHERWISE NOTED. STANDARD TOLERANCES TO APPLY UNLESS OTHERWISE SPECIFIED.

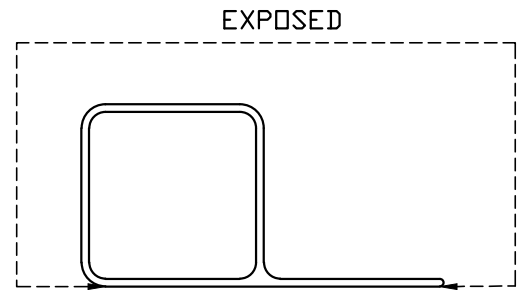
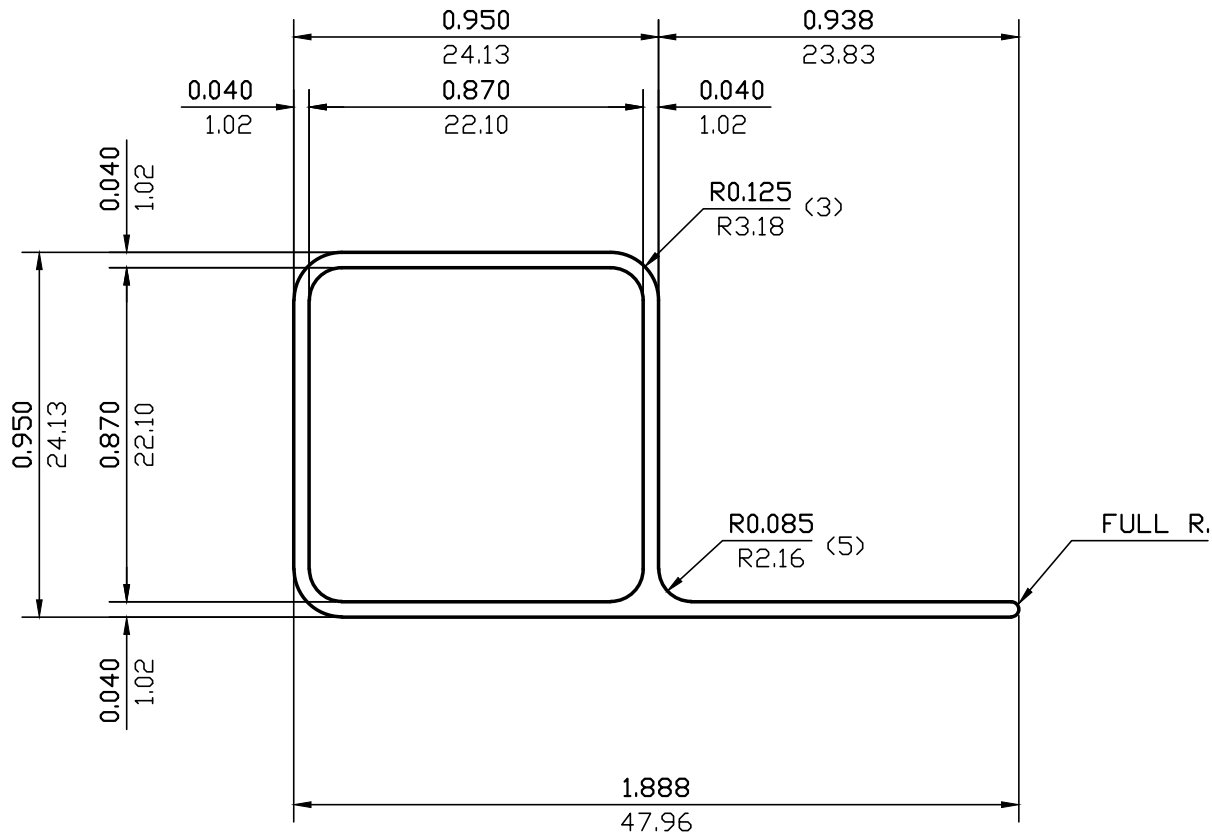

ACTUAL SIZE

WALL THICKNESS 0.040(1.02) EXCEPT AS SHOWN

DATE	REV	DESCRIPTION	BY	
EST.AREA	0.181	IN. <sup>2</sup>	EST.AREA 116.543	MM. <sup>2</sup>
EST.WT.	0.217	LBS/FT.	EST.WT. 0.323	KG/M.
EST.PER.	8.795	IN.	EST.PER. 223.405	MM.
OUT PER.	5.461	IN.	OUT PER. 138.7	MM.
C.C.D.	2.066	IN.	C.C.D. 52.479	MM.
FACTOR 41	FINISH M/F	ALLOY & TEMP. 6063		
CKD BY	SCALE 2:1	DWN BY L.G.	DATE 12/16/2002	

## CAN ART

ALUMINUM EXTRUSION INC.

428 JUTRAS DRIVE S.  
WINDSOR, ONT. N8N 5C5  
TEL. NO. (519) 727-4399  
FAX NO. (519) 727-6434  
E-MAIL: canart@canart.com

THIS DRAWING IS NOT NECESSARILY A COPY OF YOUR ORIGINAL. PLEASE APPROVE DIMENSIONS AND TOLERANCES INDICATED. CAN ART ASSUMES NO RESPONSIBILITY EITHER TECHNICAL OR LEGAL FOR HAVING THIS SHAPE MADE. THE CUSTOMER AGREES TO FULLY PROTECT CAN ART ALUMINUM FROM CLAIMS OF OTHERS RESULTING FROM THIS SHAPE.

SIGNED: \_\_\_\_\_ DATE: \_\_\_\_\_