

NOTE: BREAK ALL CORNERS WITH 0.015" (.38 MM) RADIUS UNLESS OTHERWISE NOTED. STANDARD TOLERANCES TO APPLY UNLESS OTHERWISE SPECIFIED.

CUSTOMER CAN ART OPEN	DIE No. EH15898	REV. No. 3
DESCRIPTION STILE REINFORCEMENT	CUSTOMER PART No.	QUOTE No. 08-0719-4
		PROPOSAL No. H-19595

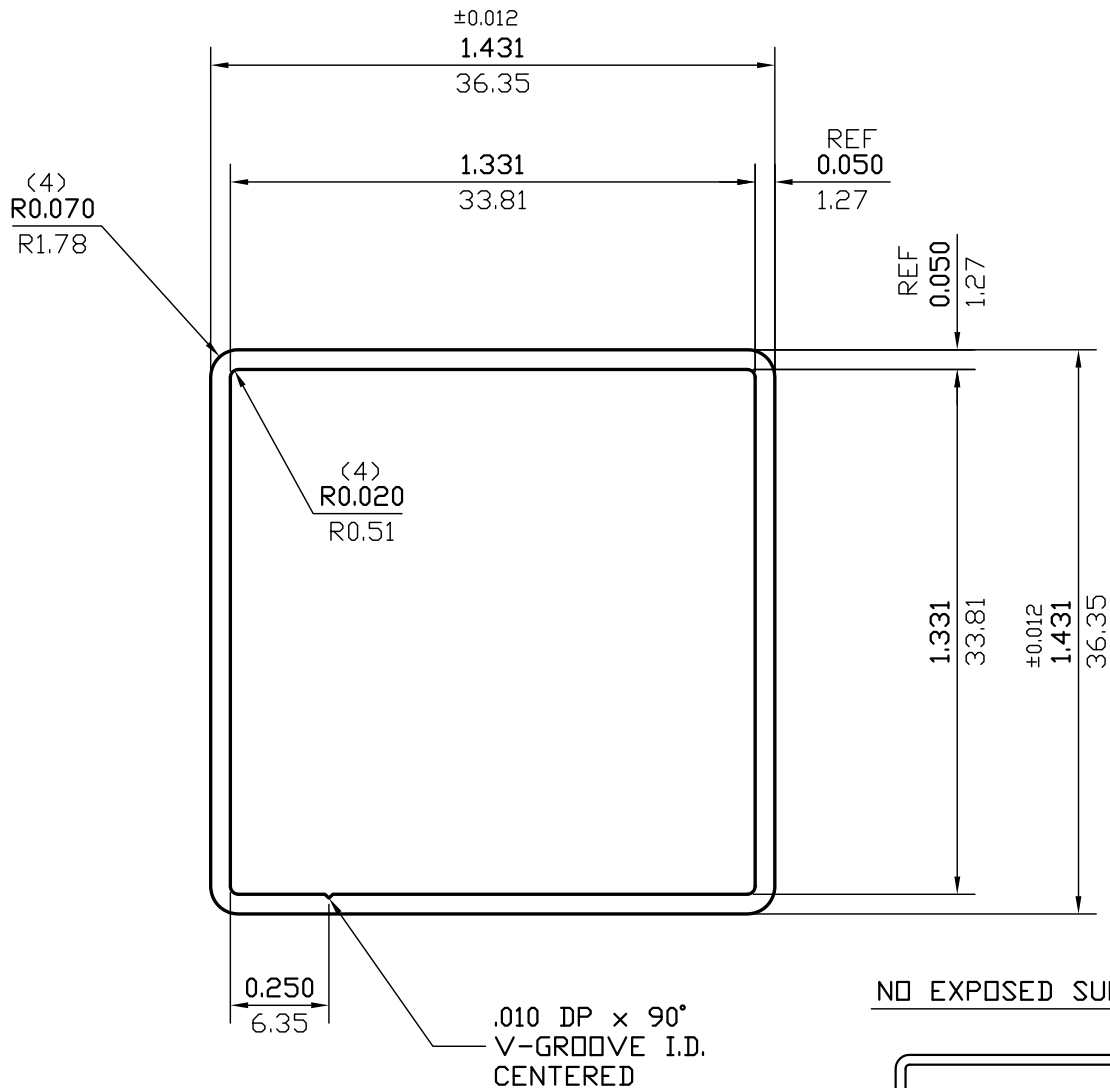

WALL THICKNESS **0.050 (1.27)** EXCEPT AS SHOWN

DATE	REV	DESCRIPTION	BY		
01/11/17	3	REVISED CUST NAME, DESCRIPTION & PART NO.	PAUL		
04/07/11	2	REVISED EXPOSED SURFACES.	PAUL		
EST.AREA	0.272	IN. ²	EST.AREA	175.716	MM. ²
EST.WT.	0.321	LBS/FT.	EST.WT.	0.478	KG/M.
EST.PER.	10.894	IN.	EST.PER.	276.715	MM.
OUT PER.	5.604	IN.	OUT PER.	142.3	MM.
C.C.D.	1.966	IN.	C.C.D.	49.934	MM.
FINISH	M/F		ALLOY	6063	
CKD BY	FACTOR 34	SCALE 2:1	DWN BY M.A.	DATE 3/9/2010	

CAN ART

85 PARKSHORE DRIVE
BRAMPTON, ONT L6T 5M1
TEL. NO. (905) 791-1464
FAX NO. (905) 791-9151
WEB: www.canart.com

ALUMINUM EXTRUSION L.P.

THIS DRAWING IS NOT NECESSARILY A COPY OF YOUR ORIGINAL. PLEASE APPROVE DIMENSIONS AND TOLERANCES INDICATED. CAN ART ASSUMES NO RESPONSIBILITY EITHER TECHNICAL OR LEGAL FOR HAVING THIS SHAPE MADE. THE CUSTOMER AGREES TO FULLY PROTECT CAN ART ALUMINUM FROM CLAIMS OF OTHERS RESULTING FROM THIS SHAPE.

SIGNED: _____ DATE: _____